

Solar Equipment & Space Requirement:
100kW System



Introduction

Photovoltaic systems offer a promising solution to combat global warming while providing sustainable energy for the future. In utility scales, solar farms are prevalent and interconnected with the grid. For enhanced efficiency and reduced loss, it is beneficial to have load and generation sources situated close to each other. Solar projects implemented in or on buildings are particularly advantageous as they harness most of the solar energy for immediate use within the building. This approach not only minimizes losses but also alleviates congestion in transmission and distribution lines.

For Building Owners

A crucial concern for building owners is the electrical equipment required for solar projects. Beyond cost considerations, they worry about the space these equipment installations demand. This document addresses the necessary equipment for various PV project sizes and scenarios.

Logistics Considerations

BIPV (Building Integrated Photovoltaics) and regular rooftop solar installations as BAPV (Building applied photovoltaics) differ in terms of installation locations, solar panel types, and mounting equipment. However, both BIPV and BAPV systems share similar components apart from the solar panels. In rooftop projects, a designated area on the flat or tilted roof is necessary. In contrast, BIPV panels replace specific building elements such as facades, windows, railings, and so on, eliminating the need for additional space.

Additional equipment, such as AC equipment, requires some space on the roof, wall, or inside the building (like electrical or mechanical room). The specific requirements for AC equipment depend on factors such as the system size, number of electricity phases (single phase or three phases), maximum DC voltages allowed in the building, and local distribution company (LDC) regulations. When inverters are placed inside the building, DC cables need to be carefully routed through conduits, necessitating penetration points in the structure. The number and size of conduits vary according to each scenario, as detailed in the accompanying table.

Required AC Equipment For Different Scenarios

Mitrex Panels, both BIPV and BAPV, are suitable for a 1000V system voltage. However, certain buildings may be restricted to a maximum of 600V DC based on local codes. Electricity services typically operate at 240V single phase or 208V, 480V, and 600V three phases. The table below outlines the required AC equipment for all the aforementioned scenarios, considering different system sizes.

600V DC MAX SYSTEM

NO. OF PHASES		SINGLE PHASE	THREE PHASE		
		● 240V	● 208V	● 480V	● 600V
5kW	Inverter	Solaredge SE5000H-US	---	---	---
	Disconnect	240V 30A Disconnect	---	---	---
	Panelboard	---	---	---	---
	Transformer	---	---	---	---
	Conduit	1" Conduit	---	---	---
	SCADA	---	---	---	---
10kW	Inverter	Solaredge SE10000H-US	Solaredge SE10KUS	Fronius Symo 15.0-3	Solaredge SE10KUS
	Disconnect	240V 60A Disconnect	240V 60A Disconnect	600V 30A Disconnect x 2	600V 30A Disconnect x 3
	Panelboard	---	---	---	---
	Transformer	---	---	---	600V/208V 15kVA TX
	Conduit	1 1/4" Conduit	1 1/4" Conduit	1 1/2" Conduit	1 1/4" Conduit
	SCADA	---	---	---	---
20kW	Inverter	Solaredge SE10000H-US x 2	Solaredge SE10KUS x 2	Fronius Symo 20.0-3	Solaredge SE10KUS x 2
	Disconnect	240V 200A Disconnect	240V 100A Disconnect	600V 30A Disconnect x 2	600V 30A Disconnect x 2
	Panelboard	240V 200A Panel	240V 100A Panel	---	600V 100A Panel
	Transformer	---	---	---	600V/208V 30kVA TX
	Conduit	1 1/2" Conduit	2" Conduit	1 1/2" Conduit	2" Conduit
	SCADA	---	---	---	---
50kW	Inverter	---	Solaredge SE17.3KUS x 3	SMA Core1 33.3kW x 2	SMA Core1 33.3kW x 2
	Disconnect	---	240V 200A Disconnect	600V 60A Disconnect x 2	600V 60A Disconnect x 2
	Panelboard	---	240V 200A Panel	600V 100A Panel	600V 100A Panel
	Transformer	---	---	---	600V/480V 75kVA TX
	Conduit	---	2" Conduit	3" or 2 x 2" Conduit	3" or 2 x 2" Conduit
	SCADA	---	Depends on the Hydro	Depends on the Hydro	Depends on the Hydro
100kW	Inverter	---	Solaredge SE17.3KUS x 6	SMA Core1 33.3kW x 3	SMA Core1 33.3kW x 3
	Disconnect	---	240V 400A Disconnect	600V 200A Disconnect x 2	600V 200A Disconnect x 2
	Panelboard	---	240V 400A Panel	600V 200A Panel	600V 200A Panel
	Transformer	---	---	---	600V/480V 150kVA TX
	Conduit	---	3" or 2 x 2" Conduit	4" or 2 x 3" or 3 x 2" Conduit	4" or 2 x 3" or 3 x 2" Conduit
	SCADA	---	Depends on the Hydro	Depends on the Hydro	Depends on the Hydro
500kW	Inverter	---	---	SMA Core1 33.3kW x 15	SMA Core1 33.3kW x 15
	Disconnect	---	---	600V 600A Disconnect x 2	600V 600A Disconnect x 2
	Panelboard	---	---	600V 800A Panel	600V 800A Panel
	Transformer	---	---	---	600V/480V 500kVA TX
	Conduit	---	---	5 x 4" Conduit	5 x 4" Conduit
	SCADA	---	---	Depends on the Hydro	Depends on the Hydro

1000V DC MAX SYSTEM

NO. OF PHASES	SINGLE PHASE	THREE PHASE			
		● 240V	● 208V	● 480V	● 600V
5kW	Inverter	Fronius Primo 5.0-1	---	---	---
	Disconnect	240V 30A Disconnect	---	---	---
	Panelboard	---	---	---	---
	Transformer	---	---	---	---
	Conduit	1 1/4" Conduit	---	---	---
	SCADA	---	---	---	---
10kW	Inverter	Fronius Primo 10.0-1	Fronius Symo 10.0-3 (208V)	Fronius Symo 10.0-3	Fronius Symo 10.0-3
	Disconnect	240V 60A Disconnect	240V 60A Disconnect	600V 30A Disconnect x 2	600V 30A Disconnect x 3
	Panelboard	---	---	---	---
	Transformer	---	---	---	600V/480V 15kVA TX
	Conduit	1 1/2" Conduit	1 1/2" Conduit	1 1/2" Conduit	1 1/2" Conduit
	SCADA	---	---	---	---
20kW	Inverter	Fronius Primo 10.0-1 x 2	Fronius Symo 10.0-3 (208V) x 2	Fronius Symo 20.0-3	Fronius Symo 20.0-3
	Disconnect	240V 200A Disconnect	240V 100A Disconnect	600V 30A Disconnect x 2	600V 30A Disconnect x 3
	Panelboard	240V 200A Panel	240V 100A Panel	---	---
	Transformer	---	---	---	600V/480V 30kVA TX
	Conduit	2" Conduit	2" Conduit	1 1/2" Conduit	1 1/2" Conduit
	SCADA	---	---	---	---
50kW	Inverter	---	Fronius Symo 15.0-3 (208V) x 3	SMA Core1 50kW	SMA Core1 50kW
	Disconnect	---	240V 200A Disconnect	600V 60A Disconnect x 2	600V 60A Disconnect x 3
	Panelboard	---	240V 200A Panel	---	---
	Transformer	---	---	---	600V/480V 75kVA TX
	Conduit	---	3" or 2 x 2" Conduit	1 1/2" Conduit	1 1/2" Conduit
	SCADA	---	Depends on the Hydro	Depends on the Hydro	Depends on the Hydro
100kW	Inverter	---	Fronius Symo 15.0-3 (208V) x 7	Solaredge SE100KUS	Solaredge SE100KUS
	Disconnect	---	240V 400A Disconnect	600V 200A Disconnect x 2	600V 200A Disconnect x 3
	Panelboard	---	240V 400A Panel	---	---
	Transformer	---	---	---	600V/480V 150kVA TX
	Conduit	---	4" or 2 x 3" or 4 x 2" Conduit	2 1/2" or 2 x 1 1/2" PVC Conduit	2 1/2" or 2 x 1 1/2" PVC Conduit
	SCADA	---	Depends on the Hydro	Depends on the Hydro	Depends on the Hydro
500kW	Inverter	---	---	Solaredge SE100KUS x 5	Solaredge SE100KUS x 5
	Disconnect	---	---	600V 600A Disconnect x 2	600V 600A Disconnect x 2
	Panelboard	---	---	600V 800A Panel	600V 800A Panel
	Transformer	---	---	600V/480V 500kVA TX	600V/480V 500kVA TX
	Conduit	---	---	2 x 4" or 5 x 2 1/2" Conduit	2 x 4" or 5 x 2 1/2" Conduit
	SCADA	---	---	Depends on the Hydro	Depends on the Hydro

Case Study

100kW System On Midrise Industrial Building

Building Type:

Industrial building with 480 panels of 300W (total 144 kW DC)

System Size:

100kW Solaredge inverter SE100KUS

System Layout:

12 strings of 40 panels with one building penetration hole (Conduit size 2 1/2")

Project Solar Equipment:

One disconnect switch 200A 600V, One 150kVA transformer 480V/600V, two more disconnect (One could be replaced with breaker inside the main building switchboard if available)

100kW System Wiring Layout:

Home Run To The Building Basement

• East Elevation

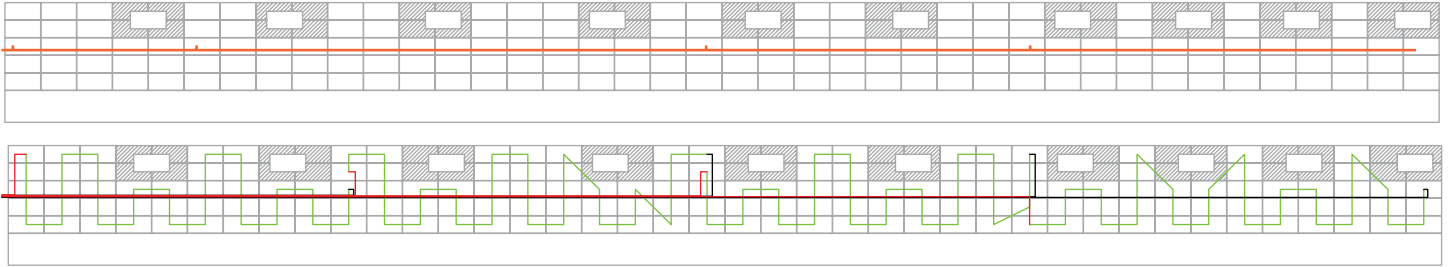

• West Elevation

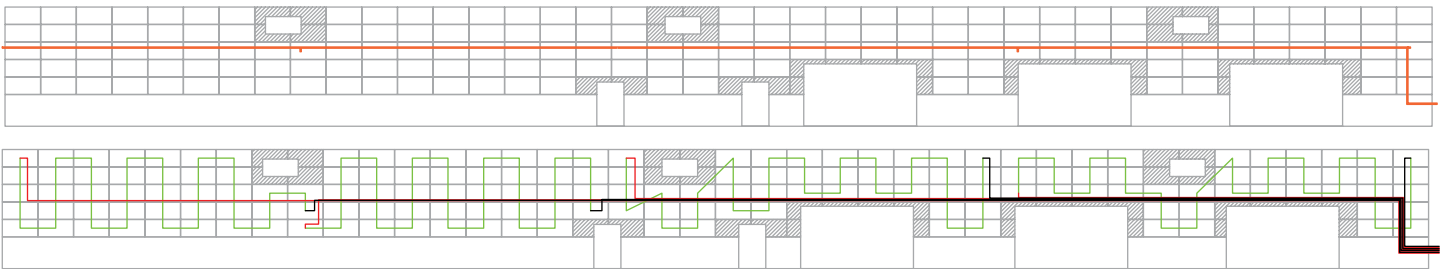

• South Elevation



• North Elevation

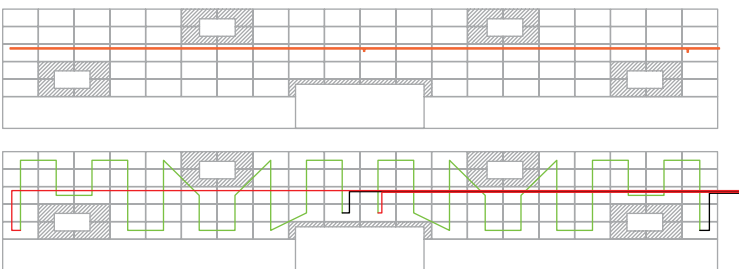

Line Colour Reference

- Building & solar panels layout
- Conduit layout
- Electrical strings
- Home run wiring

Required Space For Solar Equipment: Placed In The Basement

• Top View

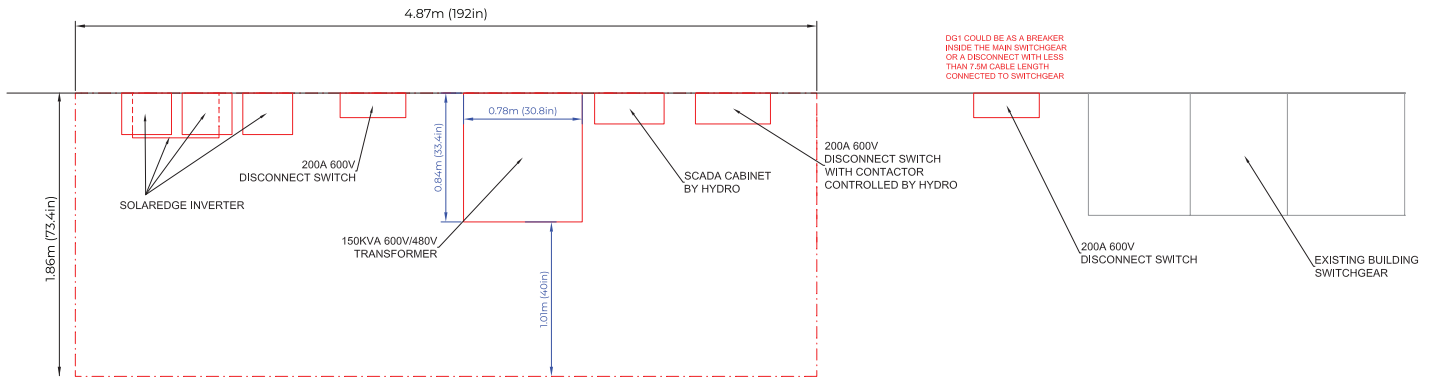

Note: Working area is 1m (39.37in) in front of solar equipments as per electrical code.

• Front View

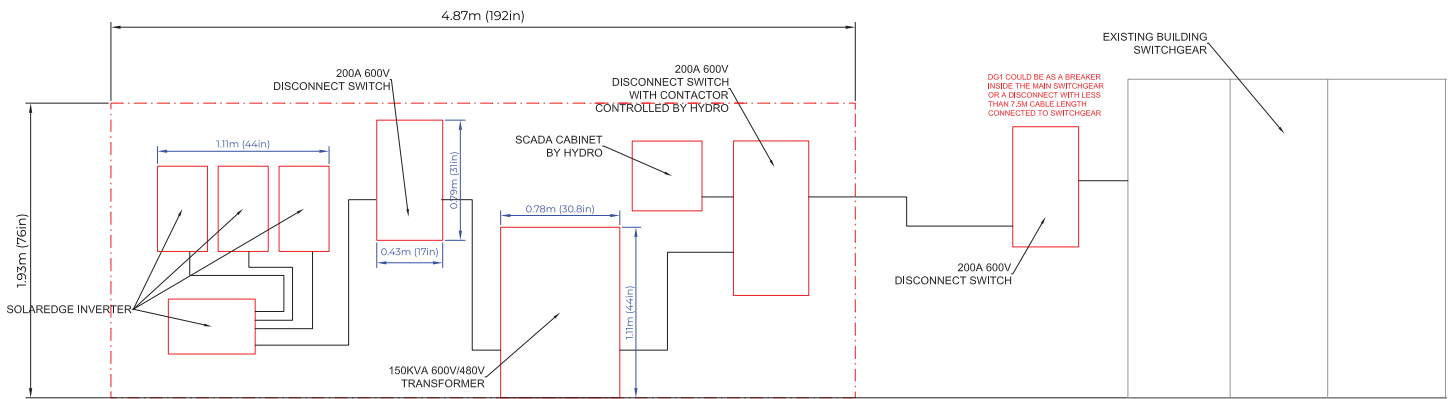

100kW System Wiring Layout:

Home Run To The Building Rooftop

• East Elevation

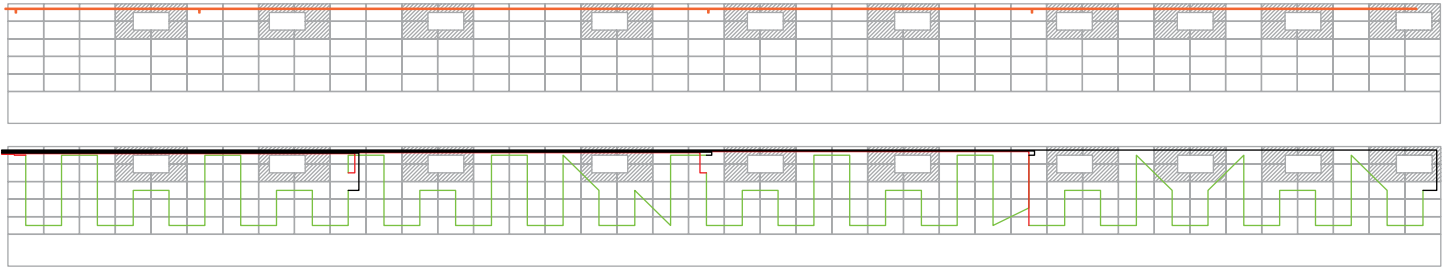

• West Elevation

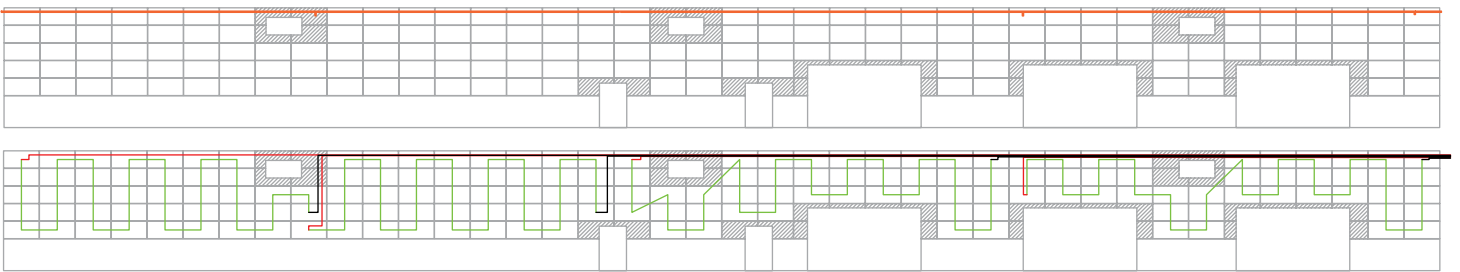

• South Elevation

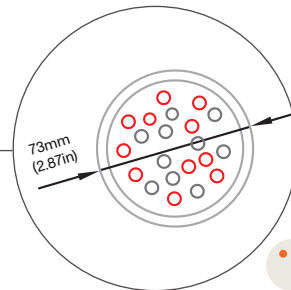

• Building Penetration For Conduit To Inverter

• North Elevation

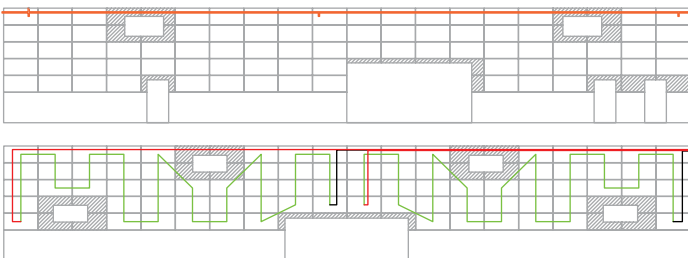

Line Colour Reference

- Building & solar panels layout
- Conduit layout
- Electrical strings
- Home run wiring

Required Space For Solar Equipment:

Placed In Rooftop

• Top View

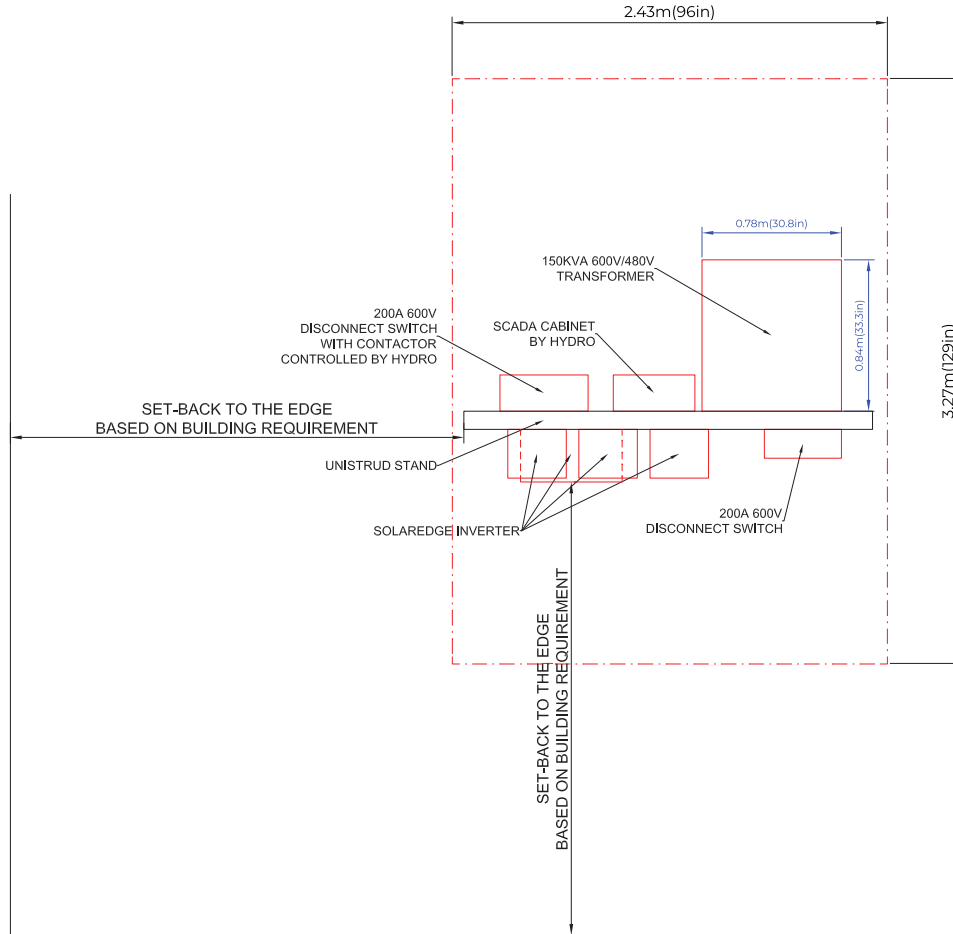

Note: Working area is 1m (39.37in) in front of solar equipments as per electrical code.

• Front View

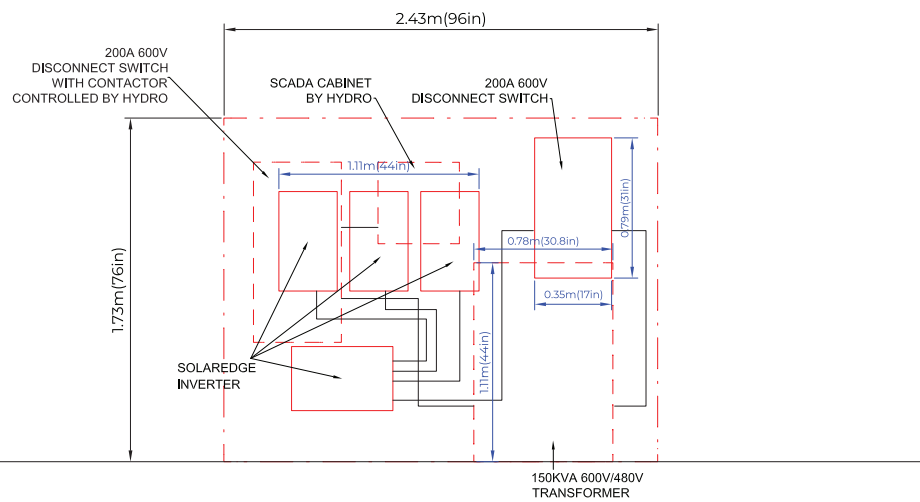

Three Phase Inverter with Synergy Technology

For the 277/480V Grid for North America

SE80KUS / SE100KUS / SE110KUS / SE120KUS



Powered by unique pre-commissioning process for rapid system installation

- Pre-commissioning feature for automated validation of system components and wiring during the site installation process and prior to grid connection
- Easy 2-person installation with lightweight, modular design (each inverter consists of 2 or 3 Synergy units and 1 Synergy Manager)
- Independent operation of each Synergy unit enables higher uptime and easy serviceability
- Built-in thermal sensors detect faulty wiring, ensuring enhanced protection and safety
- Built-in arc fault protection and rapid shutdown
- Built-in PID mitigation for maximized system performance
- Monitored* and field-replaceable surge protection devices, to better withstand surges caused by lightning or other events
- Built-in module-level monitoring with Ethernet or cellular communication for full system visibility

*Applicable only for DC and AC SPDs

/ Three Phase Inverter with Synergy Technology

For the 277/480V Grid for North America

SE80KUS / SE100KUS / SE110KUS / SE120KUS

MODEL NUMBER	SE80KUS	SE100KUS	SE110KUS	SE120KUS	
APPLICABLE TO INVERTERS WITH PART NUMBER	SExxK-USx8lxxxx				UNITS
OUTPUT					
Rated AC Active Output Power	80000	100000	110000	120000	W
Maximum AC Apparent Output Power	80000	100000	120000	120000	VA
AC Output Line Connections	3W + PE, 4W + PE				
Supported Grids	WYE: TN-C, TN-S, TN-C-S, TT, IT; Delta: IT				
AC Output Voltage Minimum-Nominal-Maximum ⁽¹⁾ (L-N)	244 – 277 – 305				Vac
AC Output Voltage Minimum-Nominal-Maximum ⁽¹⁾ (L-L)	422.5 – 480 – 529				Vac
AC Frequency Min-Nom-Max ⁽¹⁾	59.5 – 60 – 60.5				Hz
Maximum Continuous Output Current (per Phase, PF=1)	96.5	120	144.3		Aac
GFDI Threshold	1				A
Utility Monitoring, Islanding Protection, Configurable Power Factor, Country Configurable Thresholds	Yes				
Total Harmonic Distortion	≤ 3				%
Power Factor Range	+/-0.2 to 1				
INPUT					
Maximum DC Power (Module STC) Inverter / Synergy Unit	140000 / 70000	175000 / 58300	210000 / 70000		W
Transformer-less, Ungrounded	Yes				
Maximum Input Voltage DC+ to DC-	1000				Vdc
Operating Voltage Range	850 – 1000				Vdc
Maximum Input Current	2 x 48.25	3 x 40	3 x 48.25		Adc
Reverse-Polarity Protection	Yes				
Ground-Fault Isolation Detection	167kΩ sensitivity per Synergy Unit ⁽²⁾				
CEC Weighted Efficiency	98.5				%
Nighttime Power Consumption	< 8	< 12			W
ADDITIONAL FEATURES					
Supported Communication Interfaces ⁽³⁾	2 x RS485, Ethernet, Wi-Fi (optional), Cellular (optional)				
Smart Energy Management	Export Limitation				
Inverter Commissioning	With the SetApp mobile application using built-in Wi-Fi access point for local connection				
Arc Fault Protection	Built-in, User Configurable (According to UL1699B)				
Photovoltaic Rapid Shutdown System	EC 2014, 2017 and 2020, Built-in				
PID Rectifier	Nighttime, built-in				
RS485 Surge Protection (ports 1+2)	Type II, field replaceable, integrated				
AC, DC Surge Protection	Type II, field replaceable, integrated				
DC Fuses (Single Pole)	25A, integrated				
DC SAFETY SWITCH					
DC Disconnect	Built-in				
STANDARD COMPLIANCE					
Safety	UL1699B, UL1741, UL1741 SA, UL1741 SB, UL1998, CSA C22.2#107.1, Canadian AFCI according to T.I.L. M-07				
Grid Connection Standards	IEEE 1547-2018, Rule 21, Rule 14 (HI)				
Emissions	FCC part 15 class A				

(1) For other regional settings please contact SolarEdge support.

(2) Where permitted by local regulations.

(3) For specifications of the optional communication options, visit the [Communication product page](#) or the [Resource Library](#) to download the relevant product datasheet.

/ Three Phase Inverter with Synergy Technology

For the 277/480V Grid for North America

SE80KUS / SE100KUS / SE110KUS / SE120KUS

MODEL NUMBER	SE80KUS	SE100KUS	SE110KUS	SE120KUS
APPLICABLE TO INVERTERS WITH PART NUMBER	SExxK-USx8Lxxxx			UNITS
INSTALLATION SPECIFICATIONS				
Number of Synergy Units per Inverter	2	3		
Ac Max Conduit Size	2 1/2"			in
Max AWG Line / PE	4/0 / 1/0			
DC Max Conduit Size	1 x 3"; 2 x 2"			in
DC Input Inverter/ Synergy Unit	8 / 4 pairs; 6-12 AWG	12 / 4 pairs; 6-12 AWG		
	2 pairs / 1 pair, Max 2 AWG; copper or aluminum	3 pairs / 1 pair, Max 2 AWG; copper or aluminum		
Dimensions (H x W x D)	Synergy Unit: 22 x 12.9 x 10.75 / 558 x 328 x 273 Synergy Manager: 14.17 x 22.4 x 11.6 / 360 x 560 x 295			in / mm
Weight	Synergy Unit: 70.4 / 32 Synergy Manager: 39.6 / 18			lb / kg
Operating Temperature Range	-40 to +140 / -40 to +60 ⁽⁴⁾			°F / °C
Cooling	Fan (user replaceable)			
Noise	< 67			dBA
Protection Rating	NEMA 3R			
Mounting	Brackets provided			

(4) For power de-rating information refer to the [Temperature De-rating - Technical Note \(North America\)](#).

DRY TYPE TRANSFORMER SPECIFICATION

TRANSFORMER SPECIFICATION

RATING	150kVA
COOLING	ANN
TEMPERATURE RISE	115°C
PHASES	3
FREQUENCY	60Hz
K-FACTOR	4

	PRIMARY	SECONDARY
VOLTAGE	600V	480Y/277V
TAPS - FCAN	2 x 2.5%	-
TAPS - FCBN	2 x 2.5%	-
BIL	10kV	10kV

CONDUCTOR	ALUMINUM
WINDINGS	POLYESTER RESIN DIPPED
INSULATION CLASS	220°C
IMPEDANCE (@ 135°C)	3.5% - 5.0%
MIN EFFICIENCY	98.83% @ 35% LOAD, 75°C
AVG. SOUND LEVEL	50dBA
ELECTROSTATIC SHIELD	NONE
EST. WEIGHT	1320 lbs [600kg]

TERMINALS AND CABLE LUGS

	PRIMARY	SECONDARY
LOCATION	FRONT	FRONT
LINE LUGS (/PH)	1 OF 300 MCM-6 AWG	1 OF 300 MCM-6 AWG
NEUTRAL LUGS	N/A	PADS
GROUND LUG	2-14 AWG LUG ON ENCLOSURE BASE	

WIRING / CONNECTIONS

PRIMARY: H1-H2-H3		
VOLTAGE	% TAP	JUMPERS TO:
630	105.0%	1-1-1
615	102.5%	2-2-2
600	100.0%	3-3-3
585	97.5%	4-4-4
570	95.0%	5-5-5

SECONDARY: X0-X1-X2-X3		
VOLTAGE	PHASE	CONNECT LOAD TO
480	3	X1-X2-X3
277	1	X0-X1, X0-X2, AND/OR X0-X3

FEATURES

- NEOPRENE ANTI-VIBRATION PADS INSTALLED BETWEEN CORE & COIL AND ENCLOSURE BASE
- LUG FOR EARTH GROUNDING PROVIDED
- SUITABLE FOR NON-SINUSOIDAL CURRENT LOAD WITH K-FACTOR NOT TO EXCEED 4
- NEUTRAL SIZED FOR 200% OF LINE CURRENT
- SEISMIC RATED FOR USA ZONE 4 AND CANADA ZONE 6
- CSA CERTIFIED (FILE # LR34493)
- UL LISTED (FILE # E108255)
- ISO 9001 QUALITY MANAGEMENT SYSTEM
- EFFICIENCY MEETS OR EXCEEDS:
 - CANADA: SOR/DORS/2018-201 (NRCAN 2019)
 - CSA: CSA C802.2-18
 - USA: DOE 10 CFR PART 431:2016-01 (DOE 2016)

- 1) Location of nameplate and labels for Canada
 2) Location of nameplate and labels for USA
 *Recommended area for side cable entry (5"x33") on either side

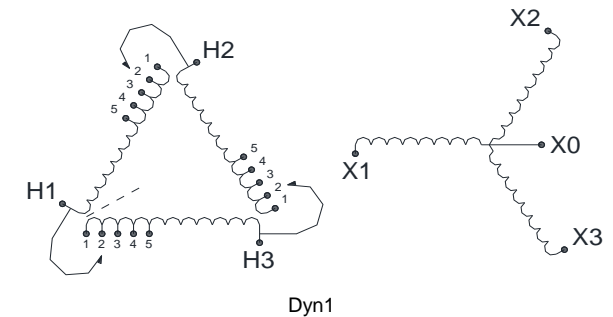
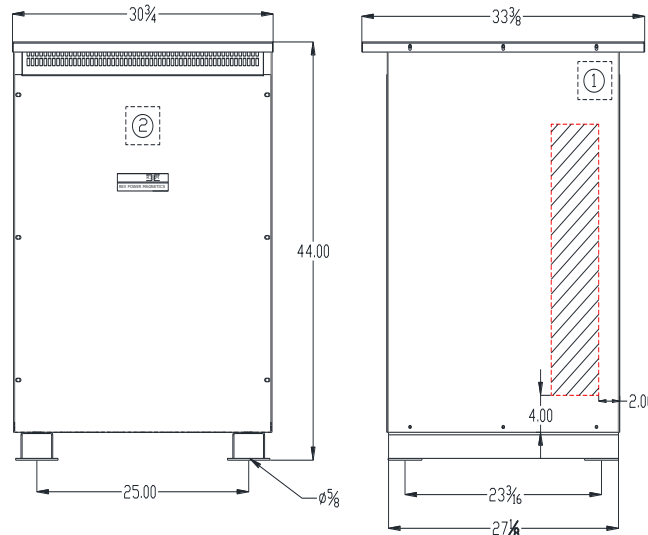

ENCLOSURE

ENCLOSURE PART #	E3R-8
ENCLOSURE RATING	TYPE 3R (INDOOR)*
CONSTRUCTION	VENTILATED
MATERIAL	STEEL
FINISH	POLYESTER POWDER COAT
COLOR	ANSI/ASA 61 (GREY)
MOUNTING	FLOOR

*SPRINKLERPROOF WHEN THE ANGLE BETWEEN SPRINKLER HEADS AND OPENING IN THE ENCLOSURE DOES NOT EXCEED 45 DEGREE FROM THE VERTICAL.

*FOR PROPER VENTILATION FOR FLOOR INSTALLATION KEEP AT LEAST 6 INCHES FROM ADJACENT WALLS

REV	REMARKS	BY	DATE	PRELIMINARY DRAWING	PRODUCT	K-FACTOR RATED ISOLATION TRANSFORMER	
				THIS DRAWING MAY NOT TRULY REFLECT OUR FINAL DESIGN. ANY ORDER(S) MUST BE ACCOMPANIED BY OR REFER TO THIS DRAWING. REX POWER MAGNETICS RESERVES THE RIGHT TO CHANGE OR REVISE THESE SPECIFICATIONS WITHOUT NOTICE	MODEL / CAT No.	BA150J-P/K4/T115/Z3	
					CUSTOMER	-	
					PO #	-	
					SWO #	-	QTY -
					Prepared By	C.G.	Date 9/21/2020
				Approved By		Date -	REX POWER MAGNETICS

Heavy Duty Safety Switches

Selection



System	Ampere Rating	Indoor — Type 1		Outdoor — Type 3R		Horsepower Rating [Ⓞ]								250 Volt DC	600 Volt DC
		Catalog Number	Ship Wt. (lbs.) Std. Pkg	Catalog Number	Ship Wt. (lbs.) Std. Pkg	480V AC		600V AC							
						1-Phase, 2-Wire	3-Phase, 3-Wire	1-Phase, 2-Wire	3-Phase, 3-Wire	1-Phase, 2-Wire	3-Phase, 3-Wire				

600 Volt Fusible[Ⓢ]

2-Pole, 2-Fuse[Ⓢ]

Ampere Rating	Catalog Number	Ship Wt. (lbs.) Std. Pkg	Catalog Number	Ship Wt. (lbs.) Std. Pkg	480 Volt AC/600 Volt AC/600 Volt DC									
					1-Phase, 2-Wire	3-Phase, 3-Wire	1-Phase, 2-Wire	3-Phase, 3-Wire	1-Phase, 2-Wire	3-Phase, 3-Wire				
30	HF261	15	HF261R	15	3	7½	—	—	3	10	—	—	5	15
60	HF262	20	HF262R	20	5	20	—	—	10	25	—	—	10	30
100	HF263	26	HF263R	27	10	30	—	—	15	40	—	—	20	50

3-Pole, 3-Fuse

Ampere Rating	Catalog Number	Ship Wt. (lbs.) Std. Pkg	Catalog Number	Ship Wt. (lbs.) Std. Pkg	480 Volt AC/600 Volt AC/250 Volt DC [Ⓢ]									
					1-Phase, 2-Wire	3-Phase, 3-Wire	1-Phase, 2-Wire	3-Phase, 3-Wire	1-Phase, 2-Wire	3-Phase, 3-Wire				
30	HF361	14	HF361R	15	3	7½	5	15	3	10	7½	20	5	—
30	HF361L [Ⓢ]	19	HF361RL [Ⓢ]	20	3	7½	5	15	3	10	7½	20	5	—
60	HF362	19	HF362R	20	5	20	15	30	10	25	15	50	10	30 [Ⓢ]
60	—	—	HF362RL [Ⓢ]	25	5	20	15	30	10	25	15	50	10	30 [Ⓢ]
100	HF363	24	HF363R	25	5	20	25	60	15	40	30	75	20	50 [Ⓢ]
200	HF364	48	HF364R	49	25	50	50	125	30	50	60	150	40	50
400	HF365A [Ⓢ]	93	HF365RA [Ⓢ]	157	—	—	100	250	—	—	125	350	50	—
600	HF366A [Ⓢ]	98	HF366RA [Ⓢ]	161	—	—	150	400	—	—	200	500	50	—
800	HF367	365	HF367R	365	—	—	200	500	—	—	250	500	50	—
1200	HF368	383	HF368R	385	—	—	200	500	—	—	250	500	50	—

3-Pole, 3-Fuse and Solid Neutral

Ampere Rating	Catalog Number	Ship Wt. (lbs.) Std. Pkg	Catalog Number	Ship Wt. (lbs.) Std. Pkg	480 Volt AC/600 Volt AC/250 Volt DC [Ⓢ]									
					1-Phase, 2-Wire	3-Phase, 3-Wire	1-Phase, 2-Wire	3-Phase, 3-Wire	1-Phase, 2-Wire	3-Phase, 3-Wire				
30	HF361N	14	HF361NR	15	3	7½	5	15	3	10	7½	20	5	—
60	HF362N	19	HF362NR	20	5	20	15	30	10	25	15	50	10	30 [Ⓢ]
100	HF363N	25	HF363NR	26	10	30	25	60	15	40	30	75	20	50 [Ⓢ]
200	HF364N	49	HF364NR	50	25	50	50	125	30	50	60	150	40	50
400	HF365NA	94.6	HF365NRA	94.6	—	—	100	250	—	—	125	350	50	—
600	HF366NA	99.6	HF366NRA	99.6	—	—	150	400	—	—	200	500	50	—
800	HF367N	375	HF367NR	375	—	—	250	500	—	—	250	500	50	—
1200	HF368N	395	HF368NR	388	—	—	250	500	—	—	250	500	50	—

600 Volt Fusible[Ⓢ] (For 2-Pole Applications use outside poles of 3-Pole Switches)

2-Pole, 2-Fuse[Ⓢ]

Ampere Rating	Type 4/4X Stainless [Ⓢ]		Type 12 Industrial [Ⓢ]		480 Volt AC/600 Volt AC/600 Volt DC									
	Catalog Number	Ship Wt. (lbs.) Std. Pkg	Catalog Number	Ship Wt. (lbs.) Std. Pkg	1-Phase, 2-Wire	3-Phase, 3-Wire	1-Phase, 2-Wire	3-Phase, 3-Wire	1-Phase, 2-Wire	3-Phase, 3-Wire				
30	HF261S	15	HF261J■	15	3	7½	—	—	3	10	—	—	5	15
60	HF262S	20	HF262J■	20	5	20	—	—	10	25	—	—	10	30
100	HF263S■	27	HF263J■	27	10	30	—	—	15	40	—	—	20	50

3-Pole, 3-Fuse

Ampere Rating	Catalog Number	Ship Wt. (lbs.) Std. Pkg	Catalog Number	Ship Wt. (lbs.) Std. Pkg	480 Volt AC/600 Volt AC/250 Volt DC [Ⓢ]									
					1-Phase, 2-Wire	3-Phase, 3-Wire	1-Phase, 2-Wire	3-Phase, 3-Wire	1-Phase, 2-Wire	3-Phase, 3-Wire				
30	HF361S	13	HF361J	14	—	—	5	15	—	—	7½	20	5	—
60	HF362S	20	HF362J	20	—	—	15	30	—	—	15	50	10	30 [Ⓢ]
100	HF363S	25	HF363J	25	—	—	25	60	—	—	30	75	20	50 [Ⓢ]
200	HF364S	49	HF364J	49	—	—	50	125	—	—	60	150	40	50
400	HF365SA [Ⓢ]	93	HF365JA [Ⓢ]	93	—	—	100	250	—	—	125	350	50	—
400	HF365SSA	93	—	—	—	—	100	250	—	—	125	350	50	—
600	HF366SA [Ⓢ]	98	HF366JA [Ⓢ]	98	—	—	150	400	—	—	200	500	50	—
600	HF366SSA	98	—	—	—	—	150	400	—	—	200	500	50	—
800	HF367S	370	HF367J■	365	—	—	200	500	—	—	250	500	50	—
1200	HF368S■	388	HF368J■	388	—	—	250	500	—	—	250	500	50	—

■ Built to order. Allow 3-5 weeks for delivery.

Ⓢ 60-600A 3-Pole switches are also rated 600V DC.

Ⓢ Height reduced switch (45.25 rather than 56 inches in height) for use with 500MCM or smaller conductors.

Ⓢ Use 3-Pole switch for 200A applications.

Ⓢ Dual horsepower ratings: Std.- applies when non-time delay fuses are installed. Max.- applies when time-delay fuses are installed.

Ⓢ Suitable for use as service entrance equipment except on 1200 Amp solidly grounded wye systems per NEC 230.95.

Ⓢ Also rated Type 3S/3R.

Ⓢ Indicates oversized enclosure (30A switch with 60A lugs in a 60A enclosure or 60A switch with 100A lugs in a 100A enclosure).

Ⓢ 600V DC & 600V DC horsepower rating shown requires (2) poles to be connected in series.

Ⓢ 304 grade stainless steel. For switches with enclosures constructed from 316 grade stainless steel, see page 4-18.

General and Heavy Duty Safety Switches

Dimensions

Safety Switch Dimensions (Inches)* & Shipping Weights

Catalog Number	Height			Width		Depth		Knockout Diagram [ⓐ]	Shipping Weight (lbs.)
	Box A	With Door B	With Rain Shed C	Box D	With Handle E	Box F	With Handle G		
HF223S also HF263S	21.96	23.16	—	9.65	12.02	5.34	10.46	—	24
HF224J	29.96	31.07	—	14.62	16.95	6.63	12.58	—	48
HF224N	29.9	31.07	—	14.62	16.98	6.36	12.33	S12	47
HF224NR	29.9	—	31.42	14.61	16.99	6.36	12.33	S13	48
HF224S	29.96	31.07	—	14.62	16.95	6.63	12.58	—	48
HF225NRA	45.32	45.81	—	22.4	23.404	6.94	9.93	S19	91.1
HF225NA	45.32	45.81	—	22.4	23.404	6.94	9.93	S18	91.1
HF226NA	45.32	45.81	—	22.4	23.404	6.94	9.93	S18	95.6
HF226NRA	45.32	45.81	—	22.4	23.404	6.94	9.93	S19	95.6
HF227N	66.67	67.16	—	38.4	39.96	9.24	14.68	—	360
HF227NR	66.67	—	67.74	38.4	39.96	9.24	14.68	—	362
HF228N	66.67	67.16	—	38.4	39.96	9.24	14.68	—	362
HF228NR	66.67	—	67.74	38.4	39.96	9.24	14.68	—	364
HF365A	45.32	45.81	—	22.4	23.404	6.94	9.93	S18	93
HF365JA	45.32	45.81	—	22.4	23.404	6.97	10.05	—	93
HF365RA	45.32	45.81	—	22.4	23.404	6.94	9.93	S19	93
HF365SA	45.32	45.81	—	22.4	23.404	7.34	10.347	—	93
HF365SSA	45.32	45.81	—	22.4	23.404	7.34	10.347	—	93
HF366A	45.32	45.81	—	22.4	23.404	6.94	9.93	S18	98
HF366JA	45.32	45.81	—	22.4	23.404	6.97	10.05	—	98
HF366RA	45.32	45.81	—	22.4	23.404	6.94	9.93	S19	98
HF366SA	45.32	45.81	—	22.4	23.404	7.34	10.347	—	98
HF366SSA	45.32	45.81	—	22.4	23.404	7.34	10.347	—	98
HF321J	14.27	17.33	—	6.65	9.02	5.32	10.46	—	14
HF321N	14.26	15.45	—	6.64	9.01	5.05	10.17	S6	14
HF321NR	14.39	—	15.77	6.64	9.01	5.05	10.17	S8	15
HF321S, SS	14.27	17.33	—	6.65	9.02	5.32	10.46	—	14
HF322J	16.27	19.31	—	9.17	11.47	5.33	10.46	—	20
HF322N	16.26	17.46	—	9.15	11.53	5.05	10.17	S16	19
HF322NR	16.26	—	17.77	9.16	11.53	5.05	10.17	S17	20
HF322S, SS	16.27	19.31	—	9.17	11.47	5.33	10.46	—	20
HF323J	21.96	23.16	—	9.65	12.02	5.34	10.46	—	25
HF323N	21.95	23.15	—	9.64	12.01	5.05	10.17	S10	25
HF323NR	21.95	—	23.46	9.64	11.97	5.05	10.17	S11	26
HF323S, SS	21.96	23.16	—	9.65	12.02	5.34	10.46	—	25
HF324J	29.96	31.07	—	14.62	16.95	6.63	12.58	—	49
HF324N	29.9	31.07	—	14.62	16.98	6.36	12.33	S12	49
HF324NR	29.9	—	31.42	14.61	16.99	6.36	12.33	S13	50
HF324S, SS	21.96	31.07	—	14.62	16.95	6.63	12.58	—	49
HF325JA	45.32	45.81	—	22.4	23.404	6.97	10.05	—	93
HF325NA	45.32	45.81	—	22.4	23.404	6.94	9.93	S18	94.6
HF325NRA	45.32	45.81	—	22.4	23.404	6.94	9.93	S19	94.6
HF325SA	45.32	45.81	—	22.4	23.404	7.34	10.347	—	93
HF325SSA	45.32	45.81	—	22.4	23.404	7.34	10.347	—	93
HF326JA	45.32	45.81	—	22.4	23.404	6.97	10.05	—	98
HF326NA	45.32	45.81	—	22.4	23.404	6.94	9.93	S18	99.6
HF326NRA	45.32	45.81	—	22.4	23.404	6.94	9.93	S19	99.6
HF326SA	45.32	45.81	—	22.4	23.404	7.34	10.347	—	98
HF326SSA	45.32	45.81	—	22.4	23.404	7.34	10.347	—	98
HF327J	66.67	67.16	—	38.4	39.96	9.24	14.68	—	367
HF327N	66.67	67.16	—	38.4	39.96	9.24	14.68	—	380
HF327NR	66.67	—	67.74	38.4	40.25	9.24	14.68	—	383
HF327S	66.67	67.16	—	38.4	39.96	9.24	14.68	—	367
HF328N	66.67	67.16	—	38.4	39.96	9.24	14.68	—	382
HF328NR	66.67	—	67.74	38.4	40.25	9.24	14.68	—	385
HF361, PV, PVPG	14.26	15.45	—	6.64	9.01	5.05	10.17	S6	14
HF361J, JW	14.27	17.33	—	6.65	9.02	5.32	10.46	—	14
HF361L	16.26	17.46	—	9.15	11.53	5.05	10.17	S16	19
HF361N	14.26	15.45	—	6.64	9.01	5.05	10.17	S6	14
HF361NR	14.39	—	15.77	6.64	9.01	5.05	10.17	S8	15
HF361R, RPV, RPVPG	14.39	—	15.77	6.64	9.01	5.05	10.17	S8	15
HF361RL, RW	16.26	—	17.77	9.16	11.53	5.05	10.17	S17	20
HF361S, SS, SSW, SW	14.27	17.33	—	6.65	9.02	5.32	10.46	—	15
HF362, PV, PVPG	16.26	17.46	—	9.15	11.53	5.05	10.17	S16	19

*For inches / millimeters conversion, multiply inches by 25.4.

[ⓐ] Knocks not provided on Type 4 / 4X and 12 or in 800 & 1200A switches.



Case Study

100kW System On Midrise Residential Building

Building Type:

Apartment building with 396 panels (portrait orientation) of 350W for each panel (total 138.6 kW DC)

System Size:

3 x SMA Core1 33.3kW inverters (total of 100kW)

System Layout:

36 strings of 11 panels with two building penetration holes (Conduit size 2x3")

Project Solar Equipment:

One AC panel of 200A 600V, ONE 150kVA transformer 480V/600V, two more disconnect.

100kW System Wiring Layout:

Home Run To The Building Basement

• East Elevation

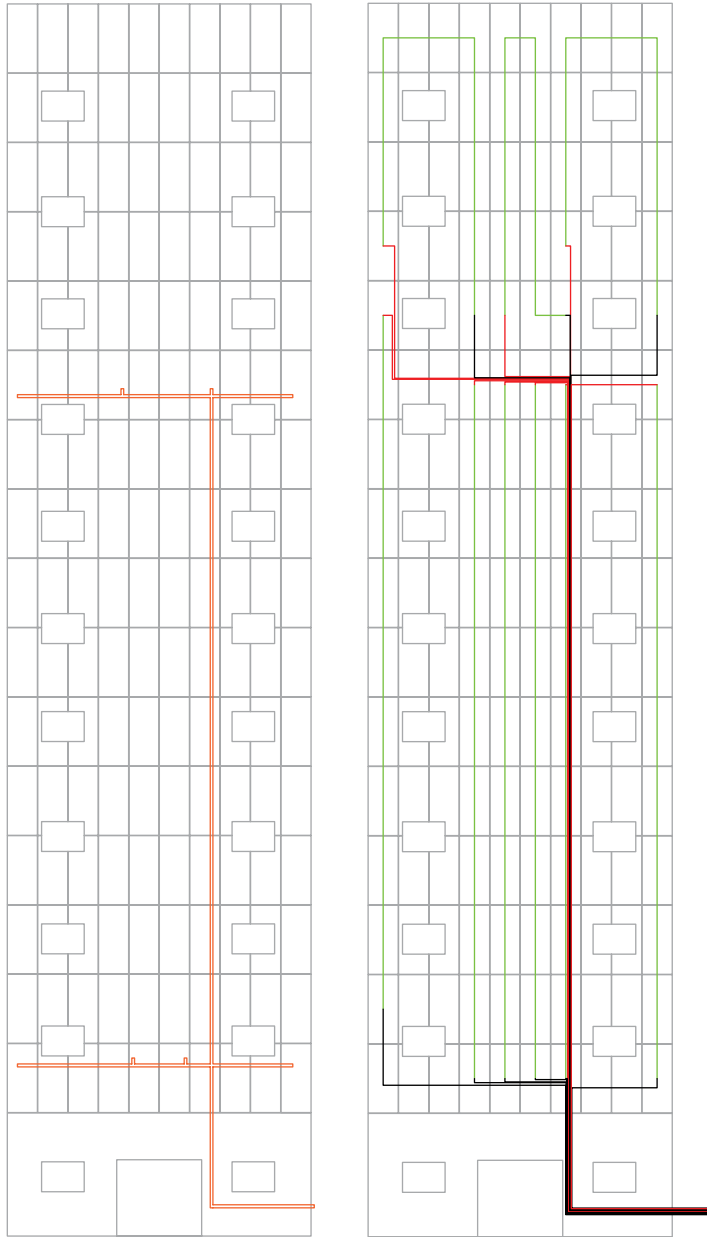

• West Elevation

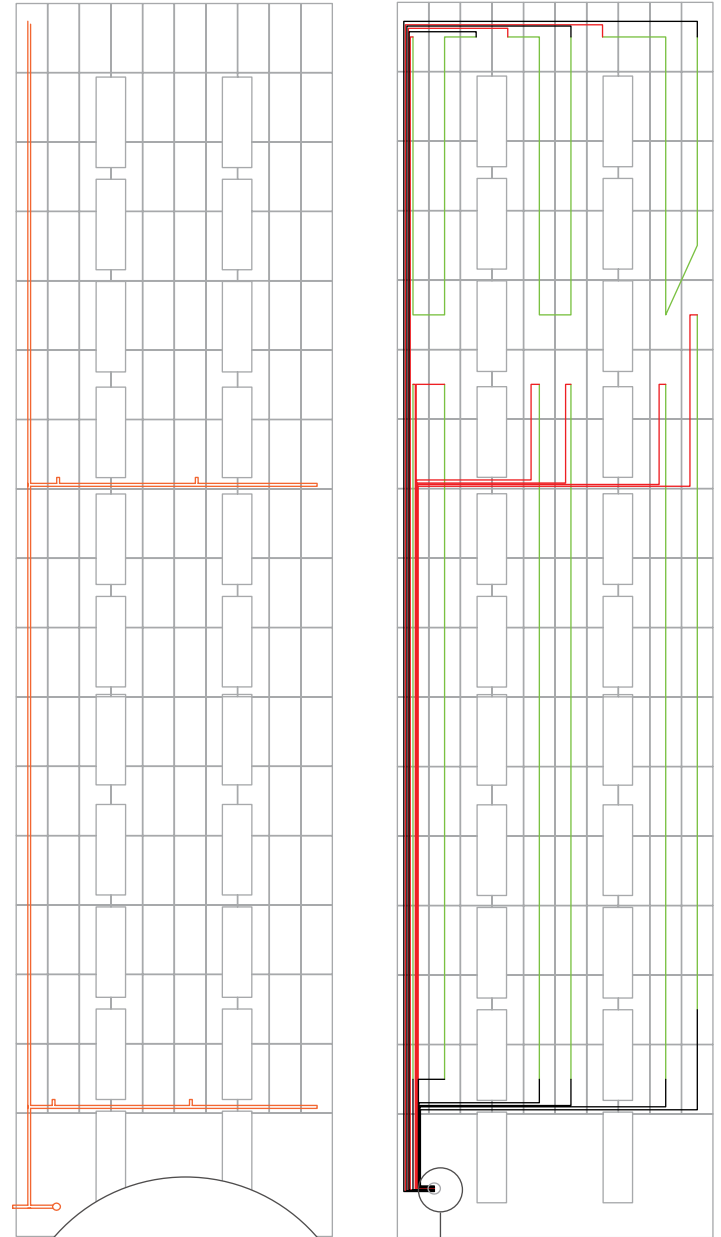

Line Colour Reference

- Building & solar panels layout
- Conduit layout
- Electrical strings
- Home run wiring

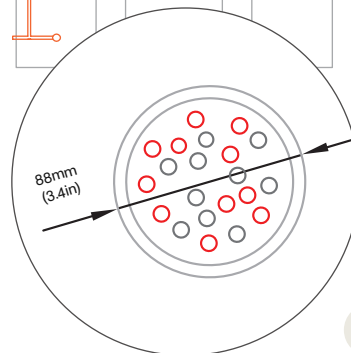

• Building Penetration For Conduit To Inverter

100kW System Wiring Layout:

Home Run To The Building Basement

• North Elevation

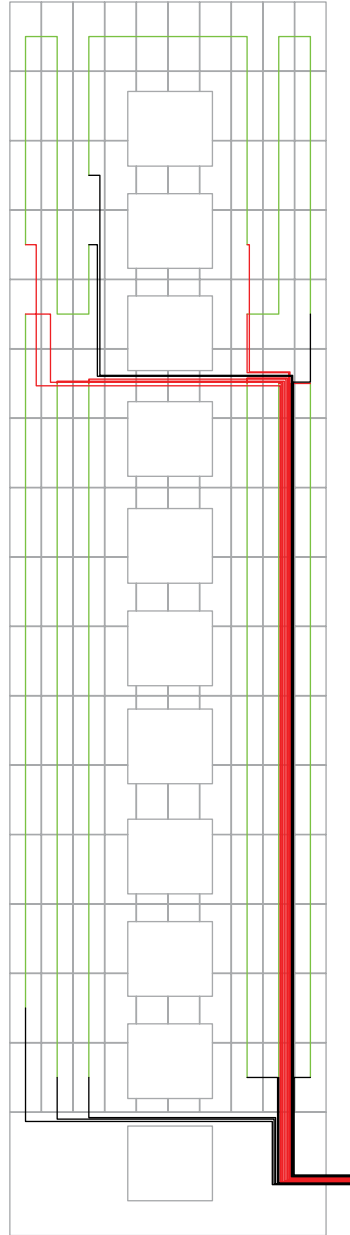
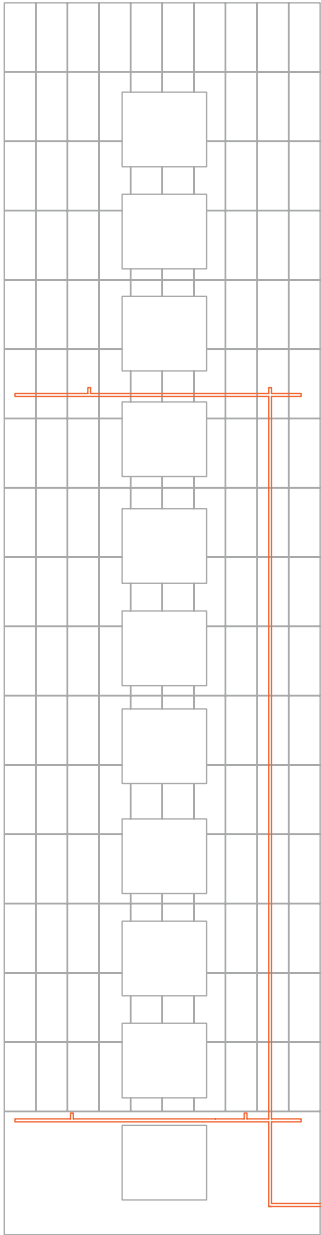

• South Elevation

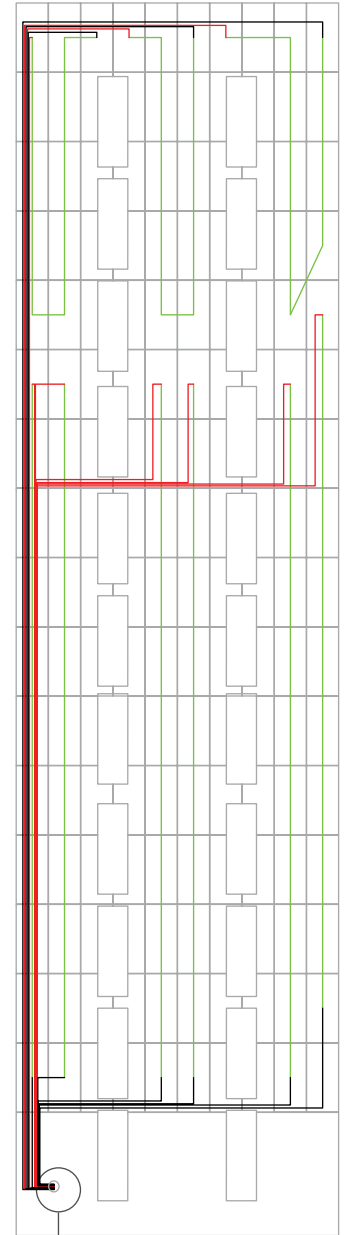
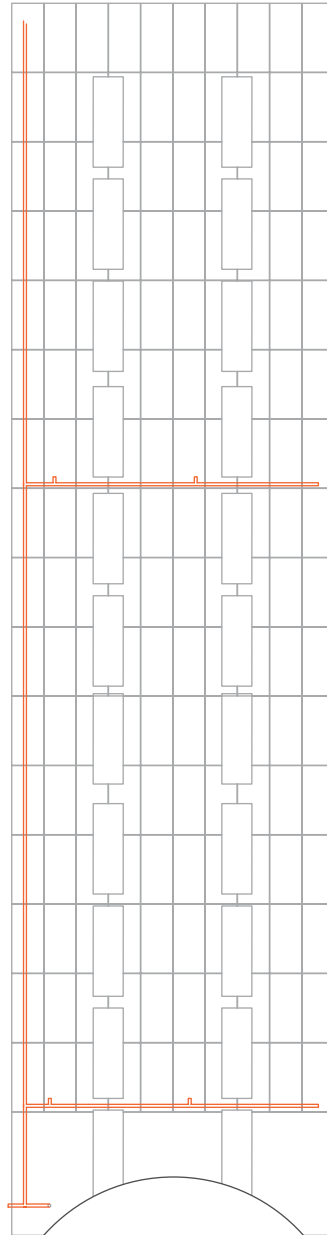

Line Colour Reference

- Building & solar panels layout
- Conduit layout
- Electrical strings
- Home run wiring

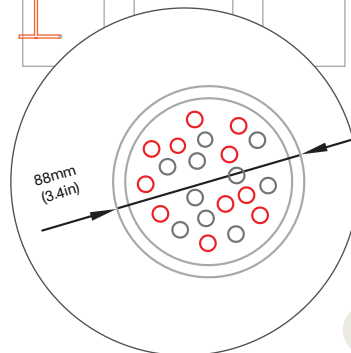

• Building Penetration For Conduit To Inverter

Required Space For Solar Equipment: Placed On The Basement

• Top View

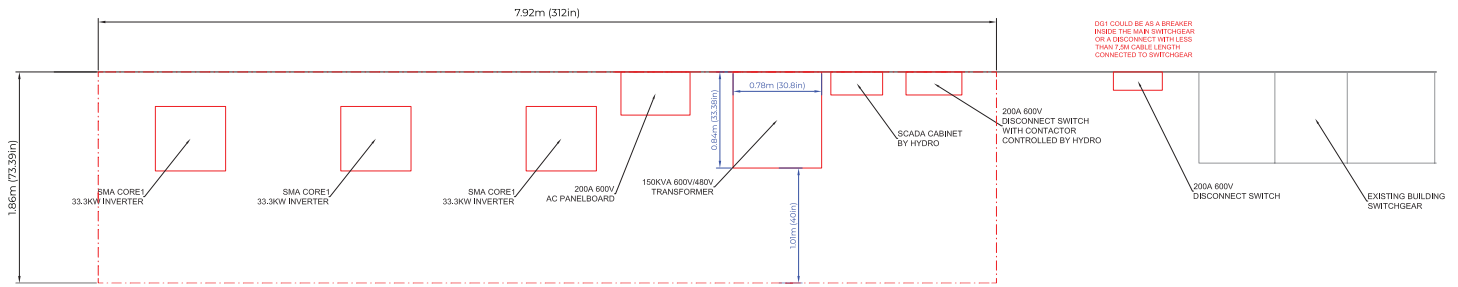

Note: Working area is 1m (39.37in) in front of solar equipments as per electrical code.

• Front View

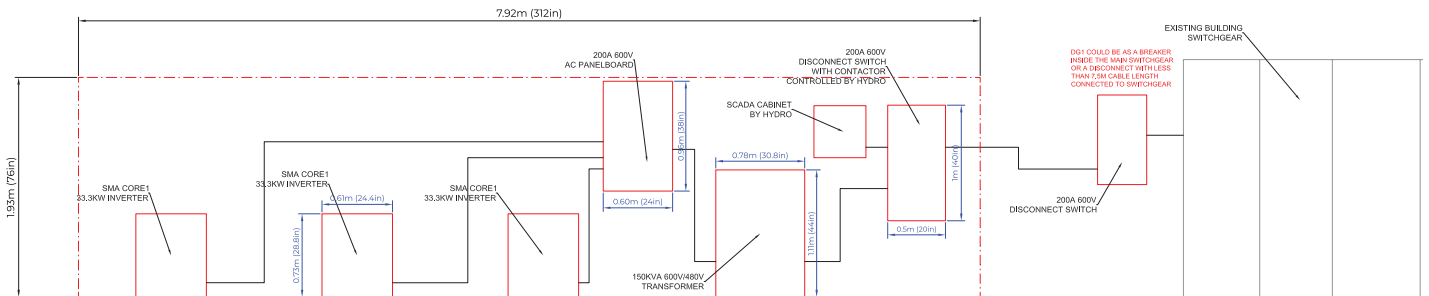

100kW System Wiring Layout:

Home Run To The Building Rooftop

• East Elevation

• West Elevation

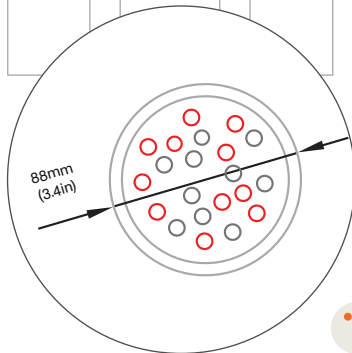
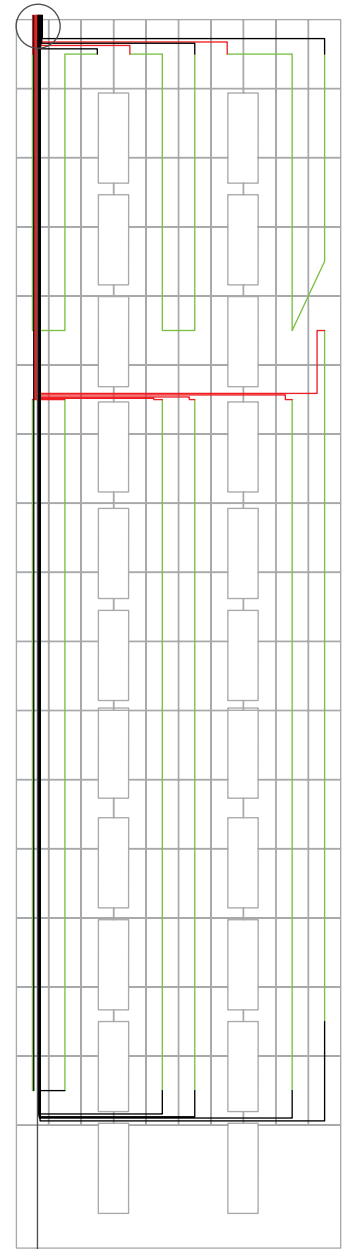
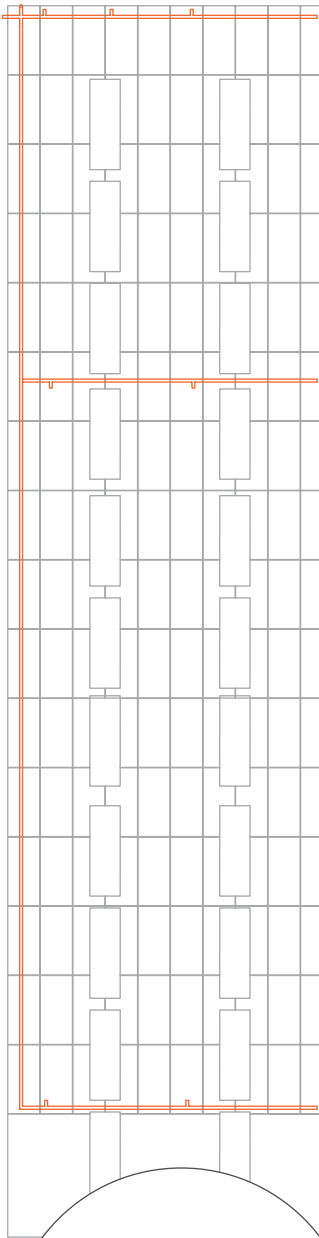
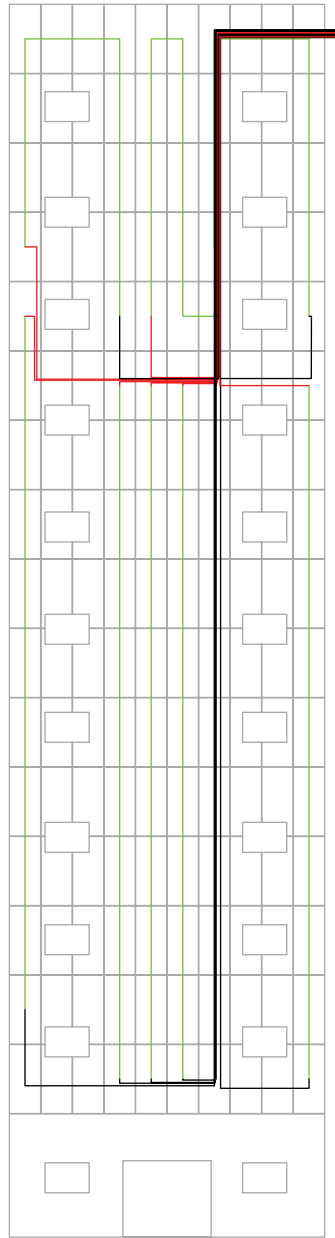
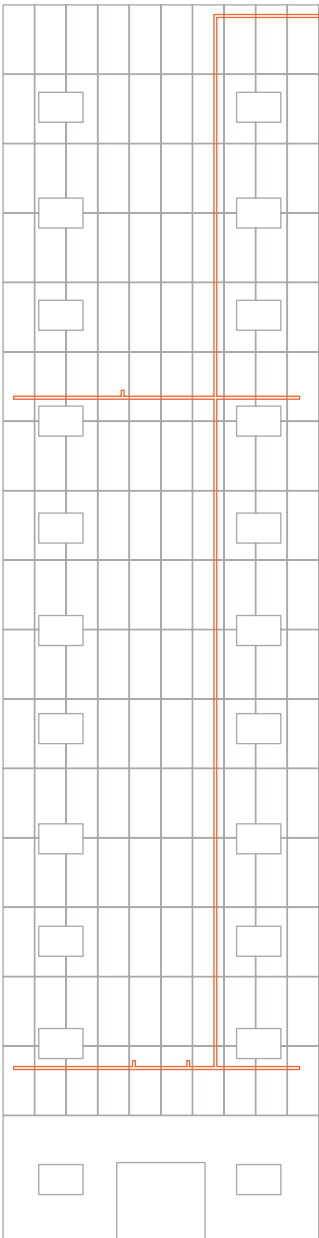

• Building Penetration For Conduit To Inverter

Line Colour Reference

- Building & solar panels layout
- Conduit layout
- Electrical strings
- Home run wiring

100kW System Wiring Layout:

Home Run To The Building Rooftop

• North Elevation

• South Elevation

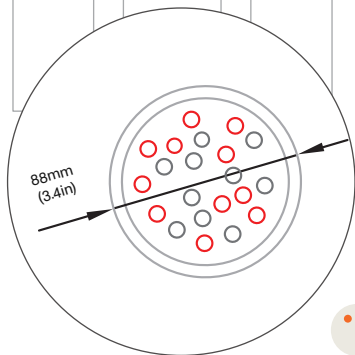
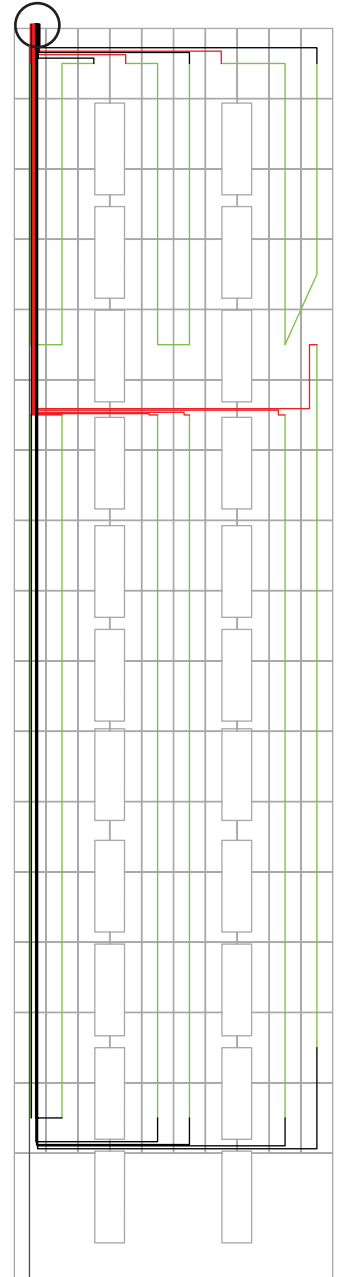
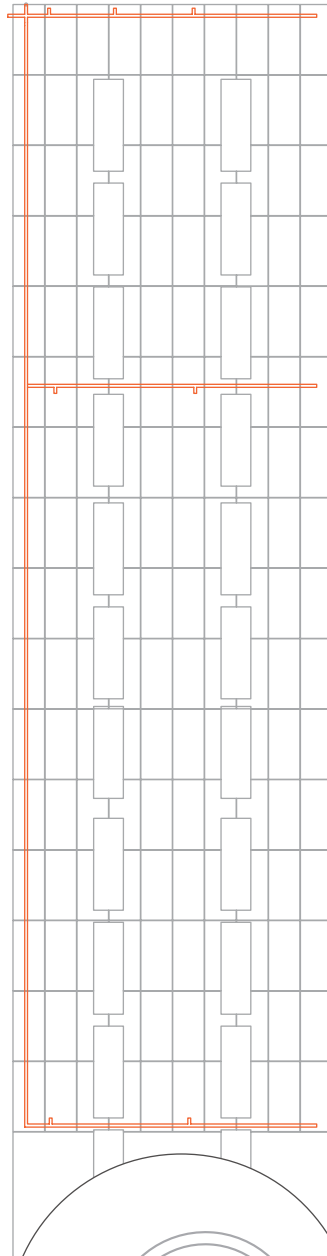
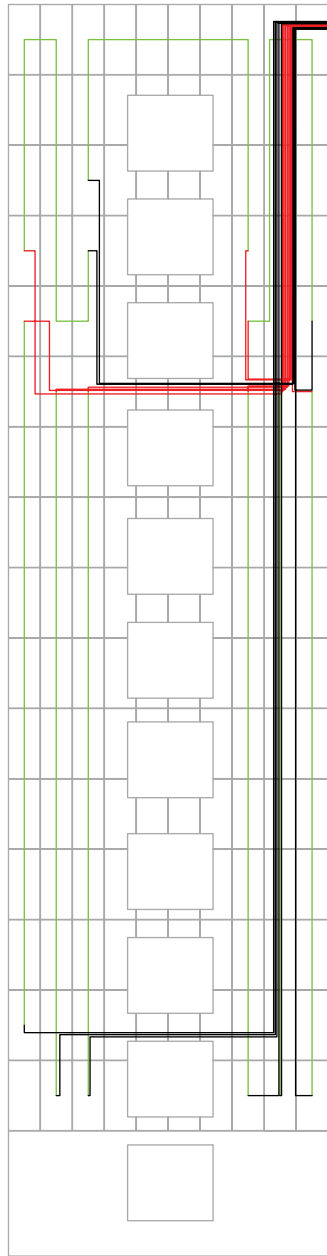
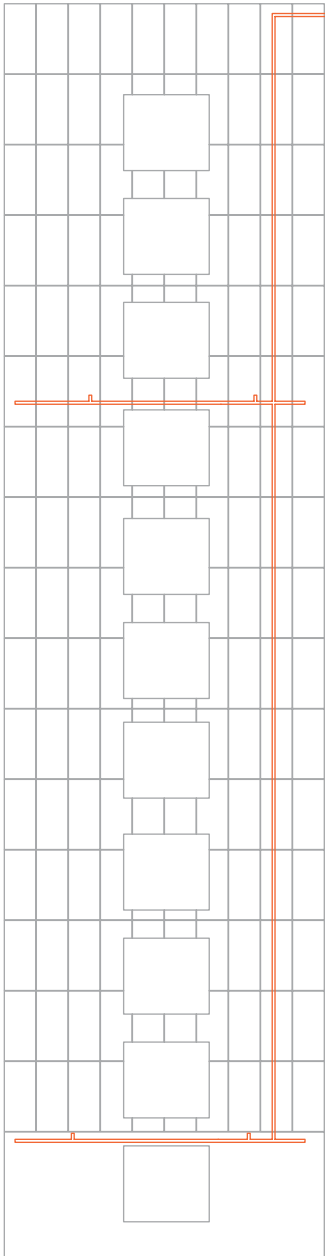

• Building Penetration For Conduit To Inverter

- Line Colour Reference**
- Building & solar panels layout
 - Conduit layout
 - Electrical strings
 - Home run wiring

Required Space For Solar Equipment:

Placed On The Rooftop

• Top View

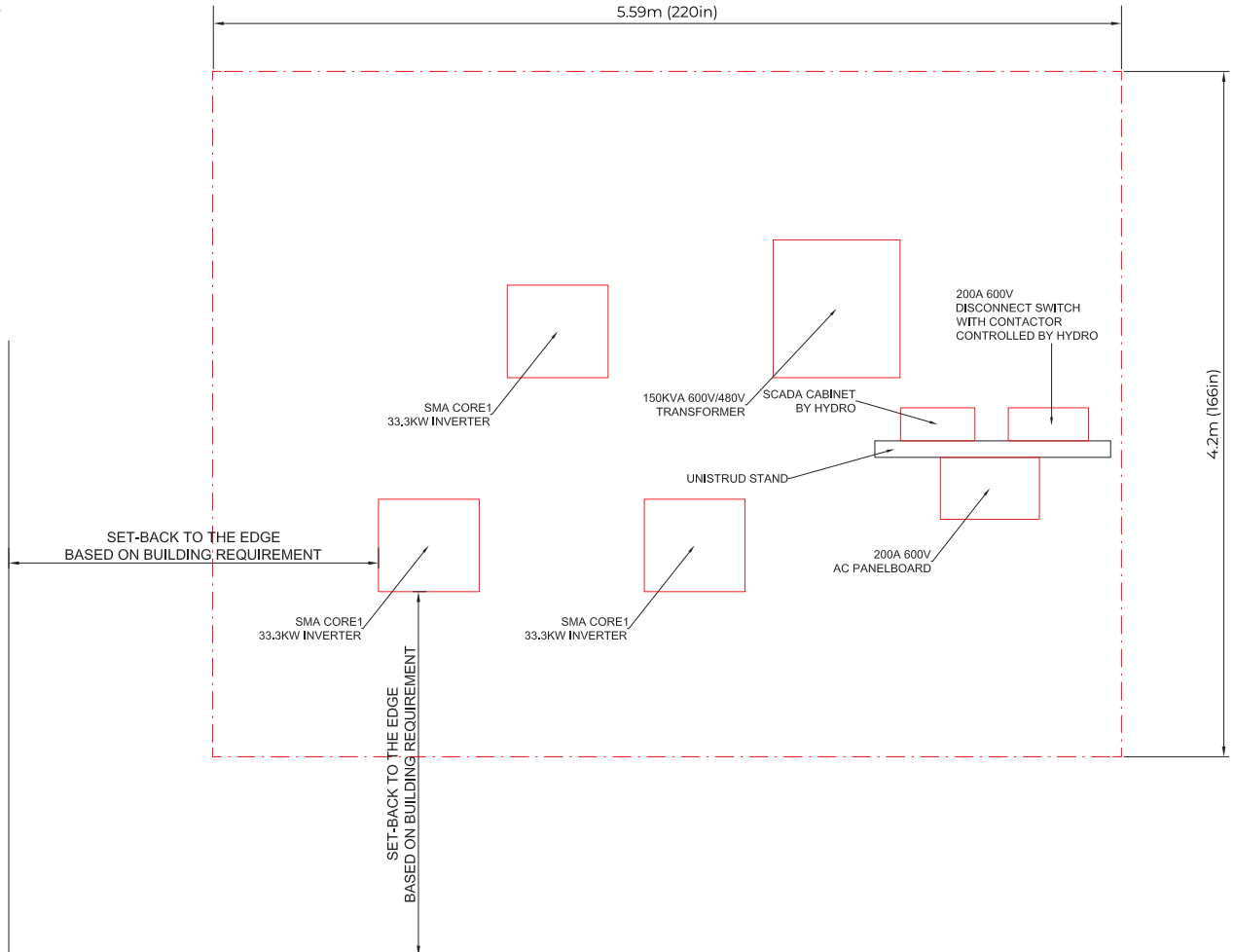

Note: Working area is 1m (39.37in) in front of solar equipments as per electrical code.

• Front View

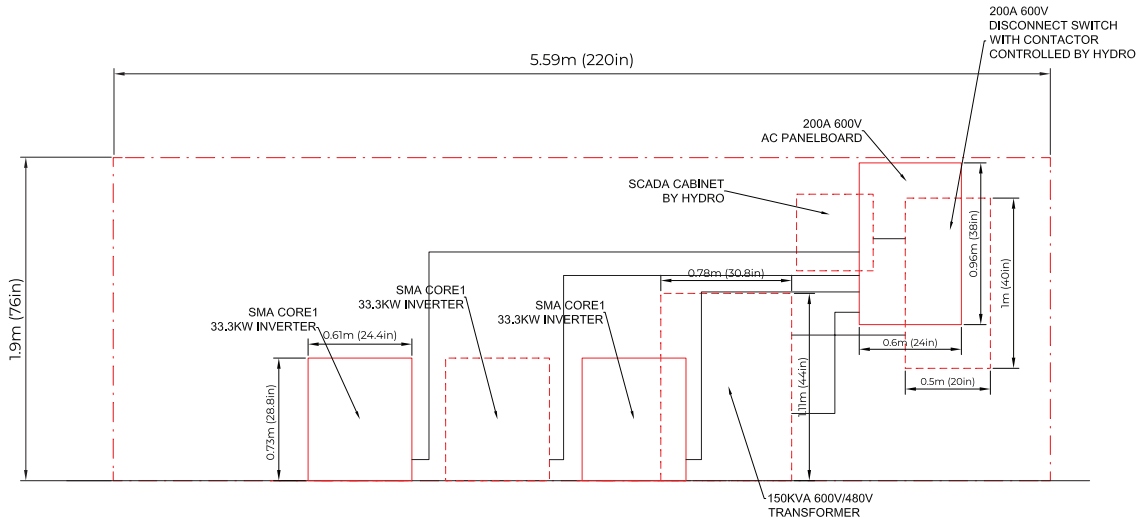



SUNNY TRIPOWER CORE1 33-US / 50-US / 62-US

STP 33-US-41 / STP 50-US-41 / STP 62-US-41

**UP TO 60% FASTER
INSTALLATION FOR
COMMERCIAL PV SYSTEMS**



Fully integrated

- Innovative design requires no additional racking for rooftop installation
- Integrated DC and AC disconnects and overvoltage protection
- 12 direct string inputs for reduced labor and material costs

Increased power, flexibility

- Multiple power ratings for small to large scale commercial PV installations
- Six MPP trackers for flexible stringing and maximum power production
- ShadeFix, SMA's proprietary shade management solution, optimizes at the string level

Enhanced safety, reliability

- Integrated SunSpec PLC signal for module-level rapid shutdown compliance to 2017 NEC
- Next-gen DC AFCI arc-fault protection certified to new Standard UL 1699B Ed. 1

Smart monitoring, control, service

- Advanced smart inverter grid support capabilities
- Increased ROI with SMA ennexOS cross sector energy management platform
- SMA Smart Connected proactive O&M solution reduces time spent diagnosing and servicing in the field

SUNNY TRIPOWER CORE1 33-US / 50-US / 62-US

It stands on its own

The Sunny Tripower CORE1 is the world's first free-standing PV inverter for commercial rooftops, carports, ground mount and repowering legacy solar projects. From distribution to construction to operation, the Sunny Tripower CORE1 enables logistical, material, labor and service cost reductions, and is the most versatile, cost-effective commercial solution available. Integrated SunSpec PLC for rapid shutdown and enhanced DC AFCI arc-fault protection ensure compliance to the latest safety codes and standards. With Sunny Tripower CORE1 and SMA's ennexOS cross sector energy management platform, system integrators can deliver comprehensive commercial energy solutions for increased ROI.

Technical data	Sunny Tripower CORE1 33-US	Sunny Tripower CORE1 50-US	Sunny Tripower CORE1 62-US
Input (DC)			
Maximum array power	50000 Wp STC	75000 Wp STC	93750 Wp STC
Maximum system voltage	1000 V		
Rated MPP voltage range	330 V... 800 V	500 V... 800 V	550 V... 800 V
MPPT operating voltage range	150 V... 1000 V		
Minimum DC voltage / start voltage	150 V / 188 V		
MPP trackers / strings per MPP input	6 / 2		
Maximum operating input current / per MPP tracker	120 A / 20 A		
Maximum short circuit current per MPPT / per string input	30 A / 30 A		
Output (AC)			
AC nominal power	33300 W	50000 W	62500 W
Maximum apparent power	33300 VA	53000 VA	66000 VA
Output phases / line connections	3 / 3-(N)-PE		
Nominal AC voltage	480 V / 277 V WYE		
AC voltage range	244 V... 305 V		
Maximum output current	40 A	64 A	80 A
Rated grid frequency	60 Hz		
Grid frequency / range	50 Hz, 60 Hz / -6 Hz... +6Hz		
Power factor at rated power / adjustable displacement	1 / 0.0 leading... 0.0 lagging		
Harmonics THD	<3%		
Efficiency			
CEC efficiency	97.5%	97.5%	97.5%
Protection and safety features			
Load rated DC disconnect	●		
Load rated AC disconnect	●		
Ground fault monitoring: Riso / Differential current	● / ●		
DC AFCI arc-fault protection	●		
SunSpec PLC signal for rapid shutdown	●		
DC reverse polarity protection	●		
AC short circuit protection	●		
DC surge protection: Type 2 / Type 1+2	○ / ○		
AC surge protection: Type 2 / Type 1+2	○ / ○		
Protection class / overvoltage category (as per UL 840)	I / IV		
General data			
Device dimensions (W/H/D)	621 mm / 733 mm / 569 mm (24.4 in x 28.8 in x 22.4 in)		
Device weight	84 kg (185 lbs)		
Operating temperature range	-25 °C... +60 °C (-13 °F... +140 °F)		
Storage temperature range	-40 °C... +70 °C (-40 °F... +158 °F)		
Audible noise emissions (full power @ 1m and 25 °C)	65 dB(A)		
Internal consumption at night	5 W		
Topology	Transformerless		
Cooling concept	OptiCool (forced convection, variable speed fans)		
Enclosure protection rating	Type 4X, 3SX (as per UL 50E)		
Maximum permissible relative humidity (non-condensing)	100%		
Additional information			
Mounting	Free-standing with included mounting feet		
DC connection	Amphenol UTX PV connectors		
AC connection	Screw terminals - 4 AWG to 4/0 AWG CU/AL		
LED indicators (Status / Fault / Communication)	●		
Network interfaces: Ethernet / WLAN / RS485	● (2 ports) / ● / ○		
Data protocols: SMA Modbus / SunSpec Modbus / Webconnect	● / ● / ●		
Multifunction relay	●		
ShadeFix technology for string level optimization	●		
Integrated Plant Control / Q on Demand 24/7	● / ●		
Off-Grid capable / SMA Fuel Save Controller compatible	● / ●		
SMA Smart Connected (proactive monitoring and service support)	●		
Certifications			
Certifications and approvals	UL 1741, UL 1699B Ed. 1, UL 1998, CSA 22.2 107-1, PV Rapid Shutdown System Equipment		
FCC compliance	FCC Part 15 Class A		
Grid interconnection standards	IEEE 1547, UL 1741 SA - CA Rule 21, HECO Rule 14H		
Advanced grid support capabilities	L/HFRT, L/HVRT, Volt-VAr, Volt-Watt, Frequency-Watt, Ramp Rate Control, Fixed Power Factor		
Warranty			
Standard	10 years		
Optional extensions	15 / 20 years		
○ Optional features ● Standard features - Not available			
Type designation	STP 33-US-41	STP 50-US-41	STP 62-US-41



SMA Data Manager M
EDMM-US-10



SMA Sensor Module
MD.SEN-US-40



Universal Mounting System
UMS_KIT-10



AC Surge Protection Module Kit
AC_SPD_KIT1-10, AC_SPD_KIT2_T1T2
DC Surge Protection Module Kit
DC_SPD_KIT4-10, DC_SPD_KIT5_T1T2

DRY TYPE TRANSFORMER SPECIFICATION

TRANSFORMER SPECIFICATION

RATING	150kVA
COOLING	ANN
TEMPERATURE RISE	115°C
PHASES	3
FREQUENCY	60Hz
K-FACTOR	4

	PRIMARY	SECONDARY
VOLTAGE	600V	480Y/277V
TAPS - FCAN	2 x 2.5%	-
TAPS - FCBN	2 x 2.5%	-
BIL	10kV	10kV

CONDUCTOR	ALUMINUM
WINDINGS	POLYESTER RESIN DIPPED
INSULATION CLASS	220°C
IMPEDANCE (@ 135°C)	3.5% - 5.0%
MIN EFFICIENCY	98.83% @ 35% LOAD, 75°C
AVG. SOUND LEVEL	50dBA
ELECTROSTATIC SHIELD	NONE
EST. WEIGHT	1320 lbs [600kg]

TERMINALS AND CABLE LUGS

	PRIMARY	SECONDARY
LOCATION	FRONT	FRONT
LINE LUGS (/PH)	1 OF 300 MCM-6 AWG	1 OF 300 MCM-6 AWG
NEUTRAL LUGS	N/A	PADS
GROUND LUG	2-14 AWG LUG ON ENCLOSURE BASE	

WIRING / CONNECTIONS

PRIMARY: H1-H2-H3		
VOLTAGE	% TAP	JUMPERS TO:
630	105.0%	1-1-1
615	102.5%	2-2-2
600	100.0%	3-3-3
585	97.5%	4-4-4
570	95.0%	5-5-5

SECONDARY: X0-X1-X2-X3		
VOLTAGE	PHASE	CONNECT LOAD TO
480	3	X1-X2-X3
277	1	X0-X1, X0-X2, AND/OR X0-X3

FEATURES

- NEOPRENE ANTI-VIBRATION PADS INSTALLED BETWEEN CORE & COIL AND ENCLOSURE BASE
- LUG FOR EARTH GROUNDING PROVIDED
- SUITABLE FOR NON-SINUSOIDAL CURRENT LOAD WITH K-FACTOR NOT TO EXCEED 4
- NEUTRAL SIZED FOR 200% OF LINE CURRENT
- SEISMIC RATED FOR USA ZONE 4 AND CANADA ZONE 6
- CSA CERTIFIED (FILE # LR34493)
- UL LISTED (FILE # E108255)
- ISO 9001 QUALITY MANAGEMENT SYSTEM
- EFFICIENCY MEETS OR EXCEEDS:
 - CANADA: SOR/DORS/2018-201 (NRCAN 2019)
 - CSA: CSA C802.2-18
 - USA: DOE 10 CFR PART 431:2016-01 (DOE 2016)

- 1) Location of nameplate and labels for Canada
 2) Location of nameplate and labels for USA
 *Recommended area for side cable entry (5"x33") on either side

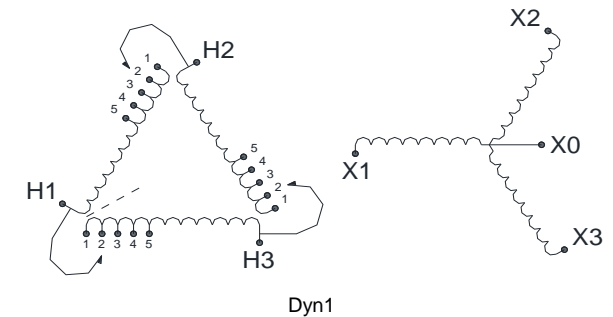
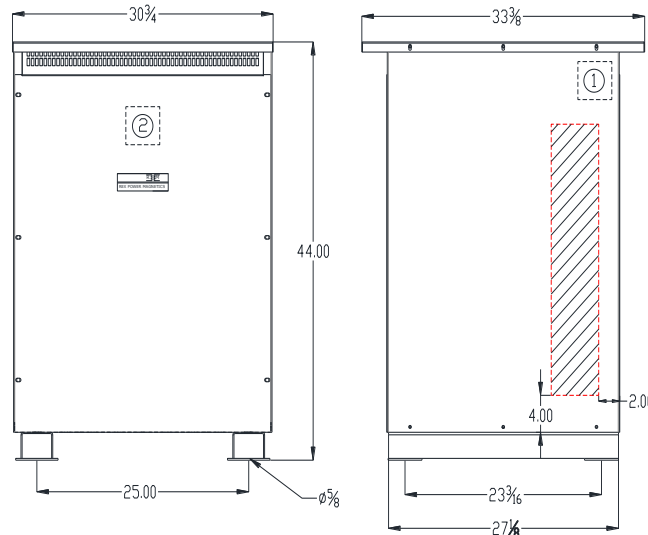

ENCLOSURE

ENCLOSURE PART #	E3R-8
ENCLOSURE RATING	TYPE 3R (INDOOR)*
CONSTRUCTION	VENTILATED
MATERIAL	STEEL
FINISH	POLYESTER POWDER COAT
COLOR	ANSI/ASA 61 (GREY)
MOUNTING	FLOOR

*SPRINKLERPROOF WHEN THE ANGLE BETWEEN SPRINKLER HEADS AND OPENING IN THE ENCLOSURE DOES NOT EXCEED 45 DEGREE FROM THE VERTICAL.

*FOR PROPER VENTILATION FOR FLOOR INSTALLATION KEEP AT LEAST 6 INCHES FROM ADJACENT WALLS

REV	REMARKS	BY	DATE	PRELIMINARY DRAWING	PRODUCT	K-FACTOR RATED ISOLATION TRANSFORMER
				THIS DRAWING MAY NOT TRULY REFLECT OUR FINAL DESIGN. ANY ORDER(S) MUST BE ACCOMPANIED BY OR REFER TO THIS DRAWING. REX POWER MAGNETICS RESERVES THE RIGHT TO CHANGE OR REVISE THESE SPECIFICATIONS WITHOUT NOTICE	MODEL / CAT No.	BA150J-P/K4/T115/Z3
					CUSTOMER	-
					PO #	-
					SWO #	- QTY -
					Prepared By	C.G. Date 9/21/2020
					Approved By	Date -



Heavy Duty Safety Switches

Selection



System	Ampere Rating	Indoor — Type 1		Outdoor — Type 3R		Horsepower Rating [Ⓞ]								250 Volt DC	600 Volt DC
		Catalog Number	Ship Wt. (lbs.) Std. Pkg	Catalog Number	Ship Wt. (lbs.) Std. Pkg	480V AC		600V AC		250 Volt DC	600 Volt DC				
						1-Phase, 2-Wire	3-Phase, 3-Wire	1-Phase, 2-Wire	3-Phase, 3-Wire						

600 Volt Fusible[Ⓢ]

2-Pole, 2-Fuse[Ⓢ]

Ampere Rating	Catalog Number	Ship Wt. (lbs.) Std. Pkg	Catalog Number	Ship Wt. (lbs.) Std. Pkg	480 Volt AC/600 Volt AC/600 Volt DC									
					1-Phase, 2-Wire	3-Phase, 3-Wire	1-Phase, 2-Wire	3-Phase, 3-Wire	250 Volt DC	600 Volt DC				
30	HF261	15	HF261R	15	3	7½	—	—	3	10	—	—	5	15
60	HF262	20	HF262R	20	5	20	—	—	10	25	—	—	10	30
100	HF263	26	HF263R	27	10	30	—	—	15	40	—	—	20	50

3-Pole, 3-Fuse

Ampere Rating	Catalog Number	Ship Wt. (lbs.) Std. Pkg	Catalog Number	Ship Wt. (lbs.) Std. Pkg	480 Volt AC/600 Volt AC/250 Volt DC [Ⓢ]									
					1-Phase, 2-Wire	3-Phase, 3-Wire	1-Phase, 2-Wire	3-Phase, 3-Wire	250 Volt DC	600 Volt DC				
30	HF361	14	HF361R	15	3	7½	5	15	3	10	7½	20	5	—
30	HF361L [Ⓢ]	19	HF361RL [Ⓢ]	20	3	7½	5	15	3	10	7½	20	5	—
60	HF362	19	HF362R	20	5	20	15	30	10	25	15	50	10	30 [Ⓢ]
60	—	—	HF362RL [Ⓢ]	25	5	20	15	30	10	25	15	50	10	30 [Ⓢ]
100	HF363	24	HF363R	25	5	20	25	60	15	40	30	75	20	50 [Ⓢ]
200	HF364	48	HF364R	49	25	50	50	125	30	50	60	150	40	50
400	HF365A [Ⓢ]	93	HF365RA [Ⓢ]	157	—	—	100	250	—	—	125	350	50	—
600	HF366A [Ⓢ]	98	HF366RA [Ⓢ]	161	—	—	150	400	—	—	200	500	50	—
800	HF367	365	HF367R	365	—	—	200	500	—	—	250	500	50	—
1200	HF368	383	HF368R	385	—	—	200	500	—	—	250	500	50	—

3-Pole, 3-Fuse and Solid Neutral

Ampere Rating	Catalog Number	Ship Wt. (lbs.) Std. Pkg	Catalog Number	Ship Wt. (lbs.) Std. Pkg	480 Volt AC/600 Volt AC/250 Volt DC [Ⓢ]									
					1-Phase, 2-Wire	3-Phase, 3-Wire	1-Phase, 2-Wire	3-Phase, 3-Wire	250 Volt DC	600 Volt DC				
30	HF361N	14	HF361NR	15	3	7½	5	15	3	10	7½	20	5	—
60	HF362N	19	HF362NR	20	5	20	15	30	10	25	15	50	10	30 [Ⓢ]
100	HF363N	25	HF363NR	26	10	30	25	60	15	40	30	75	20	50 [Ⓢ]
200	HF364N	49	HF364NR	50	25	50	50	125	30	50	60	150	40	50
400	HF365NA	94.6	HF365NRA	94.6	—	—	100	250	—	—	125	350	50	—
600	HF366NA	99.6	HF366NRA	99.6	—	—	150	400	—	—	200	500	50	—
800	HF367N	375	HF367NR	375	—	—	250	500	—	—	250	500	50	—
1200	HF368N	395	HF368NR	388	—	—	250	500	—	—	250	500	50	—

600 Volt Fusible[Ⓢ] (For 2-Pole Applications use outside poles of 3-Pole Switches)

2-Pole, 2-Fuse[Ⓢ]

Ampere Rating	Type 4/4X Stainless [Ⓢ]		Type 12 Industrial [Ⓢ]		480 Volt AC/600 Volt AC/600 Volt DC									
	Catalog Number	Ship Wt. (lbs.) Std. Pkg	Catalog Number	Ship Wt. (lbs.) Std. Pkg	1-Phase, 2-Wire	3-Phase, 3-Wire	1-Phase, 2-Wire	3-Phase, 3-Wire	250 Volt DC	600 Volt DC				
30	HF261S	15	HF261J■	15	3	7½	—	—	3	10	—	—	5	15
60	HF262S	20	HF262J■	20	5	20	—	—	10	25	—	—	10	30
100	HF263S■	27	HF263J■	27	10	30	—	—	15	40	—	—	20	50

3-Pole, 3-Fuse

Ampere Rating	Catalog Number	Ship Wt. (lbs.) Std. Pkg	Catalog Number	Ship Wt. (lbs.) Std. Pkg	480 Volt AC/600 Volt AC/250 Volt DC [Ⓢ]									
					1-Phase, 2-Wire	3-Phase, 3-Wire	1-Phase, 2-Wire	3-Phase, 3-Wire	250 Volt DC	600 Volt DC				
30	HF361S	13	HF361J	14	—	—	5	15	—	—	7½	20	5	—
60	HF362S	20	HF362J	20	—	—	15	30	—	—	15	50	10	30 [Ⓢ]
100	HF363S	25	HF363J	25	—	—	25	60	—	—	30	75	20	50 [Ⓢ]
200	HF364S	49	HF364J	49	—	—	50	125	—	—	60	150	40	50
400	HF365SA [Ⓢ]	93	HF365JA [Ⓢ]	93	—	—	100	250	—	—	125	350	50	—
400	HF365SSA	93	—	—	—	—	100	250	—	—	125	350	50	—
600	HF366SA [Ⓢ]	98	HF366JA [Ⓢ]	98	—	—	150	400	—	—	200	500	50	—
600	HF366SSA	98	—	—	—	—	150	400	—	—	200	500	50	—
800	HF367S	370	HF367J■	365	—	—	200	500	—	—	250	500	50	—
1200	HF368S■	388	HF368J■	388	—	—	250	500	—	—	250	500	50	—

■ Built to order. Allow 3-5 weeks for delivery.

Ⓢ 60-600A 3-Pole switches are also rated 600V DC.

Ⓢ Height reduced switch (45.25 rather than 56 inches in height) for use with 500MCM or smaller conductors.

Ⓢ Use 3-Pole switch for 200A applications.

Ⓢ Dual horsepower ratings: Std.- applies when non-time delay fuses are installed. Max.- applies when time-delay fuses are installed.

Ⓢ Suitable for use as service entrance equipment except on 1200 Amp solidly grounded wye systems per NEC 230.95.

Ⓢ Also rated Type 3S/3R.

Ⓢ Indicates oversized enclosure (30A switch with 60A lugs in a 60A enclosure or 60A switch with 100A lugs in a 100A enclosure).

Ⓢ 600V DC & 600V DC horsepower rating shown requires (2) poles to be connected in series.

Ⓢ 304 grade stainless steel. For switches with enclosures constructed from 316 grade stainless steel, see page 4-18.

General and Heavy Duty Safety Switches

Dimensions

Safety Switch Dimensions (Inches)* & Shipping Weights

Catalog Number	Height			Width		Depth		Knockout Diagram [Ⓞ]	Shipping Weight (lbs.)
	Box A	With Door B	With Rain Shed C	Box D	With Handle E	Box F	With Handle G		
HF223S also HF263S	21.96	23.16	—	9.65	12.02	5.34	10.46	—	24
HF224J	29.96	31.07	—	14.62	16.95	6.63	12.58	—	48
HF224N	29.9	31.07	—	14.62	16.98	6.36	12.33	S12	47
HF224NR	29.9	—	31.42	14.61	16.99	6.36	12.33	S13	48
HF224S	29.96	31.07	—	14.62	16.95	6.63	12.58	—	48
HF225NRA	45.32	45.81	—	22.4	23.404	6.94	9.93	S19	91.1
HF225NA	45.32	45.81	—	22.4	23.404	6.94	9.93	S18	91.1
HF226NA	45.32	45.81	—	22.4	23.404	6.94	9.93	S18	95.6
HF226NRA	45.32	45.81	—	22.4	23.404	6.94	9.93	S19	95.6
HF227N	66.67	67.16	—	38.4	39.96	9.24	14.68	—	360
HF227NR	66.67	—	67.74	38.4	39.96	9.24	14.68	—	362
HF228N	66.67	67.16	—	38.4	39.96	9.24	14.68	—	362
HF228NR	66.67	—	67.74	38.4	39.96	9.24	14.68	—	364
HF365A	45.32	45.81	—	22.4	23.404	6.94	9.93	S18	93
HF365JA	45.32	45.81	—	22.4	23.404	6.97	10.05	—	93
HF365RA	45.32	45.81	—	22.4	23.404	6.94	9.93	S19	93
HF365SA	45.32	45.81	—	22.4	23.404	7.34	10.347	—	93
HF365SSA	45.32	45.81	—	22.4	23.404	7.34	10.347	—	93
HF366A	45.32	45.81	—	22.4	23.404	6.94	9.93	S18	98
HF366JA	45.32	45.81	—	22.4	23.404	6.97	10.05	—	98
HF366RA	45.32	45.81	—	22.4	23.404	6.94	9.93	S19	98
HF366SA	45.32	45.81	—	22.4	23.404	7.34	10.347	—	98
HF366SSA	45.32	45.81	—	22.4	23.404	7.34	10.347	—	98
HF321J	14.27	17.33	—	6.65	9.02	5.32	10.46	—	14
HF321N	14.26	15.45	—	6.64	9.01	5.05	10.17	S6	14
HF321NR	14.39	—	15.77	6.64	9.01	5.05	10.17	S8	15
HF321S, SS	14.27	17.33	—	6.65	9.02	5.32	10.46	—	14
HF322J	16.27	19.31	—	9.17	11.47	5.33	10.46	—	20
HF322N	16.26	17.46	—	9.15	11.53	5.05	10.17	S16	19
HF322NR	16.26	—	17.77	9.16	11.53	5.05	10.17	S17	20
HF322S, SS	16.27	19.31	—	9.17	11.47	5.33	10.46	—	20
HF323J	21.96	23.16	—	9.65	12.02	5.34	10.46	—	25
HF323N	21.95	23.15	—	9.64	12.01	5.05	10.17	S10	25
HF323NR	21.95	—	23.46	9.64	11.97	5.05	10.17	S11	26
HF323S, SS	21.96	23.16	—	9.65	12.02	5.34	10.46	—	25
HF324J	29.96	31.07	—	14.62	16.95	6.63	12.58	—	49
HF324N	29.9	31.07	—	14.62	16.98	6.36	12.33	S12	49
HF324NR	29.9	—	31.42	14.61	16.99	6.36	12.33	S13	50
HF324S, SS	21.96	31.07	—	14.62	16.95	6.63	12.58	—	49
HF325JA	45.32	45.81	—	22.4	23.404	6.97	10.05	—	93
HF325NA	45.32	45.81	—	22.4	23.404	6.94	9.93	S18	94.6
HF325NRA	45.32	45.81	—	22.4	23.404	6.94	9.93	S19	94.6
HF325SA	45.32	45.81	—	22.4	23.404	7.34	10.347	—	93
HF325SSA	45.32	45.81	—	22.4	23.404	7.34	10.347	—	93
HF326JA	45.32	45.81	—	22.4	23.404	6.97	10.05	—	98
HF326NA	45.32	45.81	—	22.4	23.404	6.94	9.93	S18	99.6
HF326NRA	45.32	45.81	—	22.4	23.404	6.94	9.93	S19	99.6
HF326SA	45.32	45.81	—	22.4	23.404	7.34	10.347	—	98
HF326SSA	45.32	45.81	—	22.4	23.404	7.34	10.347	—	98
HF327J	66.67	67.16	—	38.4	39.96	9.24	14.68	—	367
HF327N	66.67	67.16	—	38.4	39.96	9.24	14.68	—	380
HF327NR	66.67	—	67.74	38.4	40.25	9.24	14.68	—	383
HF327S	66.67	67.16	—	38.4	39.96	9.24	14.68	—	367
HF328N	66.67	67.16	—	38.4	39.96	9.24	14.68	—	382
HF328NR	66.67	—	67.74	38.4	40.25	9.24	14.68	—	385
HF361, PV, PVPG	14.26	15.45	—	6.64	9.01	5.05	10.17	S6	14
HF361J, JW	14.27	17.33	—	6.65	9.02	5.32	10.46	—	14
HF361L	16.26	17.46	—	9.15	11.53	5.05	10.17	S16	19
HF361N	14.26	15.45	—	6.64	9.01	5.05	10.17	S6	14
HF361NR	14.39	—	15.77	6.64	9.01	5.05	10.17	S8	15
HF361R, RPV, RPVPG	14.39	—	15.77	6.64	9.01	5.05	10.17	S8	15
HF361RL, RW	16.26	—	17.77	9.16	11.53	5.05	10.17	S17	20
HF361S, SS, SSW, SW	14.27	17.33	—	6.65	9.02	5.32	10.46	—	15
HF362, PV, PVPG	16.26	17.46	—	9.15	11.53	5.05	10.17	S16	19

*For inches / millimeters conversion, multiply inches by 25.4.

Ⓞ Knocks not provided on Type 4 / 4X and 12 or in 800 & 1200A switches.

Application

Type P1 Panelboards

Table P1-3 – Main Breaker Panel Size Selector

Maximum Ampere Rating	Main Breaker Types	Max. No. of Poles	Dimensions in Inches (mm)		
			Unit Space A	Box Height B	Weight In lbs. (kg)
100	BL, BLH	18 30 42	9 (229)	32 (813)	105 (48)
	HBL		15 (381)	38 (965)	120 (55)
	BQD		21 (533)	44 (1118)	135 (61)
125	NGB		9 (229)	32 (813)	110 (50)
			15 (381)	38 (965)	125 (57)
			21 (533)	44 (1118)	140 (64)
225	ED2, ED4, ED6, HED4, HED6		9 (229)	32 (813)	110 (50)
			15 (381)	38 (965)	125 (57)
			21 (533)	44 (1118)	140 (64)
250	QJ2		9 (229)	32 (813)	110 (50)
	QJH2		15 (381)	38 (365)	125 (57)
	QJ2-H		21 (533)	44 (1118)	140 (64)
250	FXD6	9 (229)	32 (813)	115 (52)	
	FD6	15 (381)	38 (965)	130 (59)	
	HFD6, HFXD6	21 (533)	44 (1118)	145 (66)	
≤ 250	MLO	9 (229)	32 (813)	115 (52)	
		15 (381)	38 (365)	125 (57)	
		21 (533)	44 (1118)	135 (61)	
400	JD6, JXD6	18 30 42	9 (229)	56 (1422)	172 (78)
	HJD6		15 (381)	62 (1575)	190 (86)
	HJXD6		21 (533)	68 (1727)	208 (95)
			9 (229)	56 (1422)	115 (52)
	MLO		15 (381)	62 (1575)	130 (59)
			21 (533)	68 (1722)	145 (66)

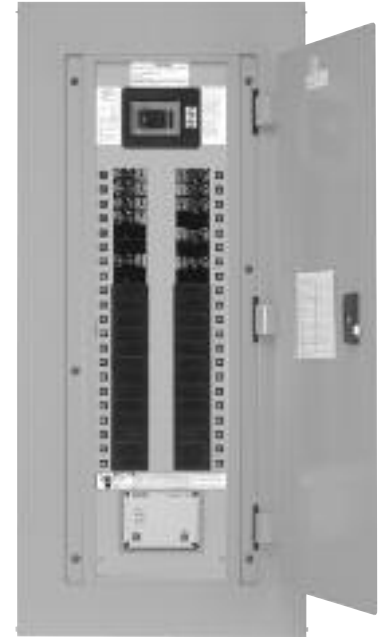

Note: Main breakers use breaker connectors. For sizes, see breaker connector chart. 400 amp main breaker panel has wire bending space for 600 kcmil cables as standard. Use 750 Kcmil lug if 600 Kcmil cable is to be used.

Table P1-4 – Main Breaker Selection

Ampere Rating	Breaker Type	Max. IR (kA) at		Additional Trip Values
		240V AC	480/277V AC	
100	BL (STD)	10	—	15, 20, 25, 30, 35, 40, 45, 50, 60, 70, 80, 90, 100
	BLH	22	—	15, 20, 25, 30, 35, 40, 45, 50, 60, 70, 80, 90, 100
	HBL	65	—	15, 20, 25, 30, 35, 40, 45, 50, 60, 70, 80, 90, 100
	BQD	65	14	15, 20, 25, 30, 35, 40, 45, 50, 60, 70, 80, 90, 100
125	NGB (STD)	100	25	50, 60, 70, 80, 90, 100, 110, 125
	ED4 (STD)	65	25	50, 60, 70, 80, 90, 100, 110, 125
	HED4	100	42	50, 60, 70, 80, 90, 100, 110, 125
225	QJ2 (STD)	10	—	60, 70, 80, 90, 100, 110, 125, 150, 175, 200, 225
	QJH2	22	—	60, 70, 80, 90, 100, 110, 125, 150, 175, 200, 225
	QJ2-H	42	—	60, 70, 80, 90, 100, 110, 125, 150, 175, 200, 225
	HQJ2H	100	—	60, 70, 80, 90, 100, 110, 125, 150, 175, 200, 225
250	FXD6 (STD)	65	35	70, 80, 90, 100, 110, 125, 150, 175, 200, 225, 250
	FD6	65	35	70, 80, 90, 100, 110, 125, 150, 175, 200, 225, 250
	HFD6	100	65	70, 80, 90, 100, 150, 175, 200, 225, 250
	HFXD6	100	65	70, 80, 90, 100, 110, 125, 150, 175, 200, 225, 250
400	JXD6 (STD)	65	35	200, 225, 250, 300, 350, 400
	JD6	65	35	200, 225, 250, 300, 350, 400
	HJD6	100	65	200, 225, 250, 300, 350, 400
	HJXD6	100	65	200, 225, 250, 300, 350, 400

Dimensions

Type P1 Panelboards

Type 1 Box

Box is symmetrical

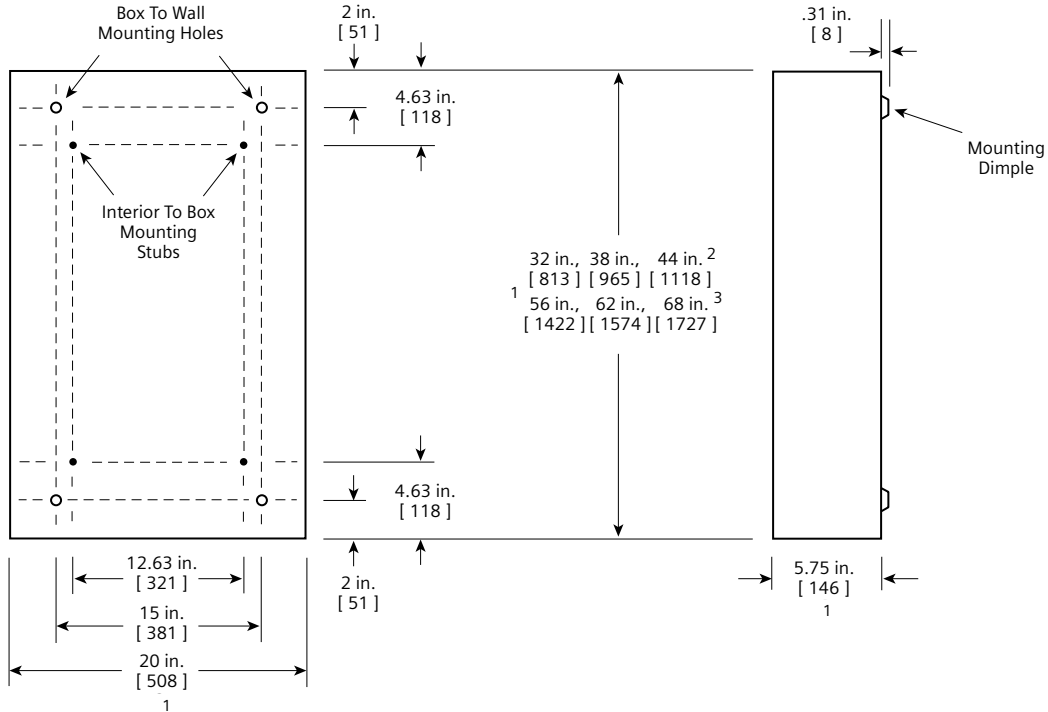

Type 3R and 3R/12 Box

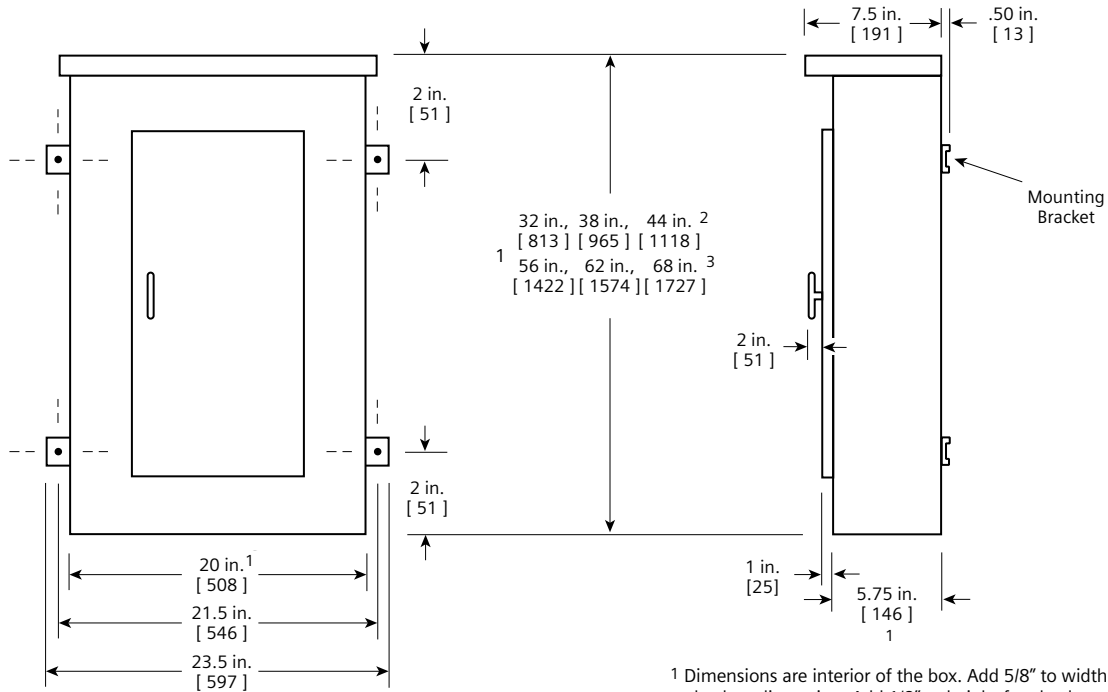

¹ Dimensions are interior of the box. Add 5/8" to width for absolute dimension. Add 1/8" to height for absolute dimension.

² 250 Amp panel.

³ 400 Amp panel.

Dimensions shown in inches and millimeters [].

- **Toll Free**

+1 (855) 254 0214

- **Learn More**

mitrex.com

info@mitrex.com

- **Headquarters**

41 Racine Rd, Toronto, ON M9W2Z4, Canada

+1 (416) 497 7120

- **USA Office**

Chrysler Building, 405 Lexington Avenue Floor 26, New York, USA, 10174

+1 (646) 583 4486

